

European Style Press Brake Tooling

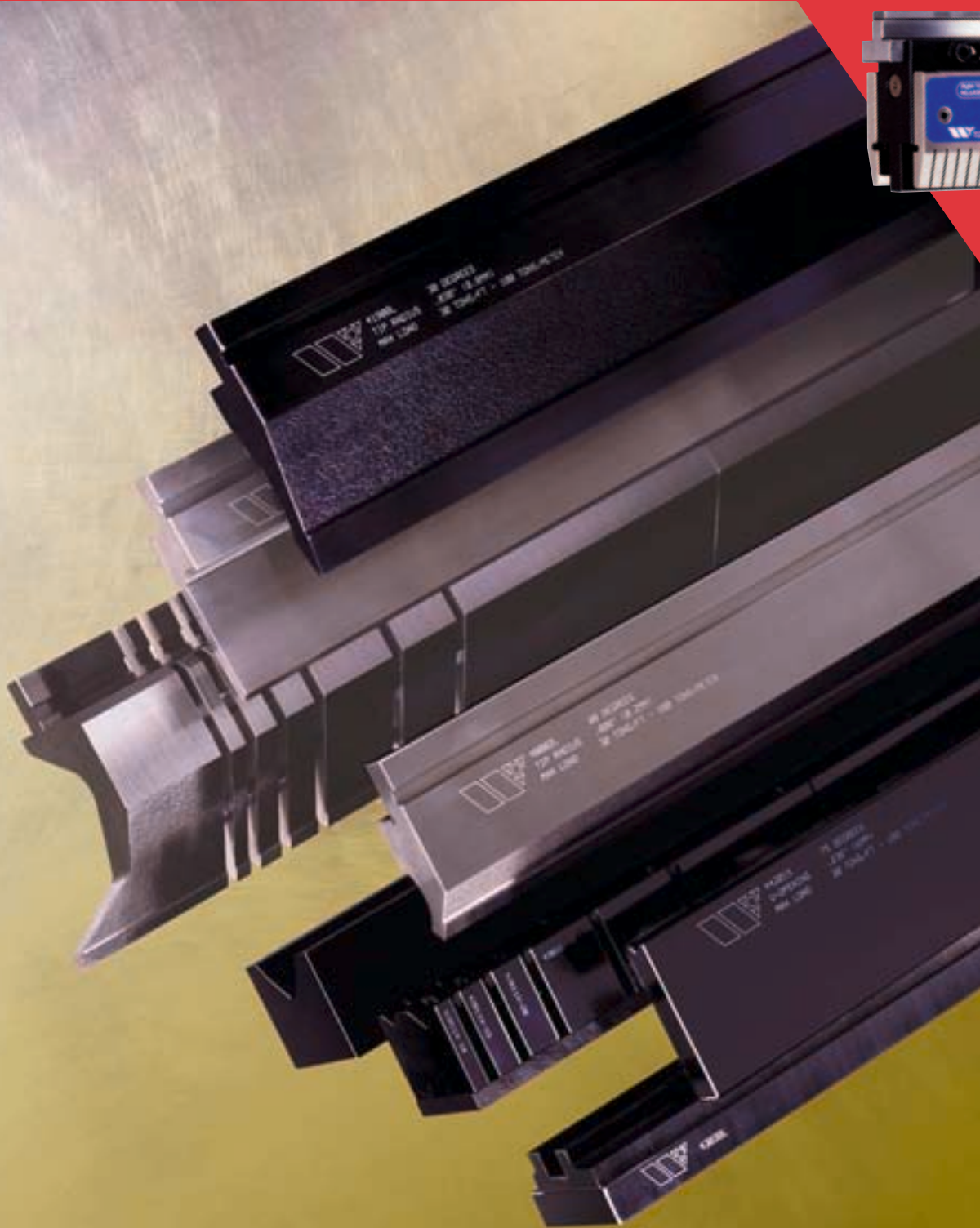

Extend The Life Of Your Tools With Nitrex™

Nitrex™ high endurance surface enhancement, exclusively from Wilson Tool, increases press brake tooling life by several times that of standard tooling. With a surface hardness of HRC-60 and a consistent 0.51mm of penetration below the surface of the tool, Nitrex™ adds lubricity to press brake tooling and lowers the coefficient of friction as the material slides over the shoulder of the V-opening on a die. Any Wilson Tool press brake punch or die can be enhanced with Nitrex™.

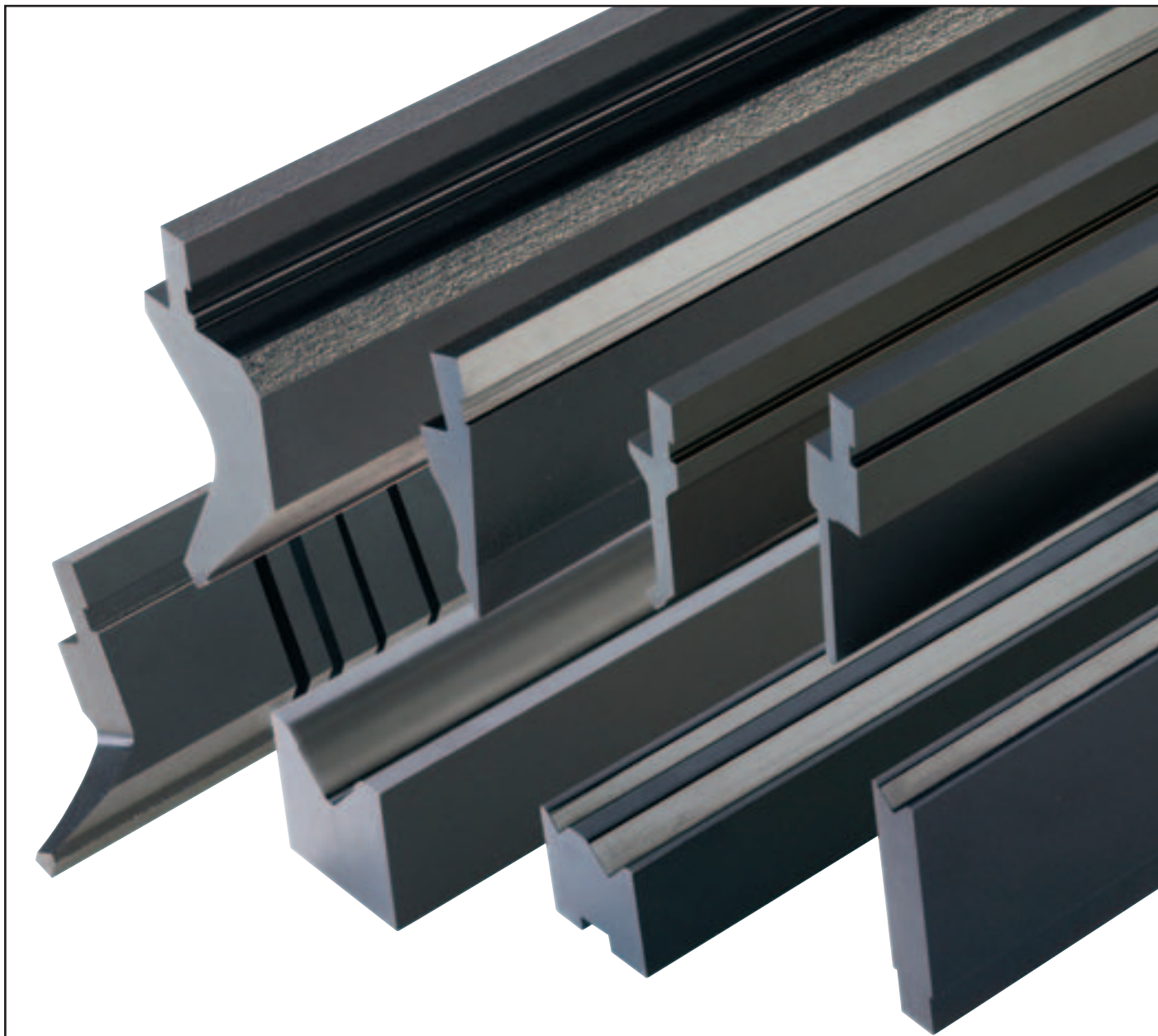

Most Wilson Tool press brake dies now come with NITREX™ as standard at no extra cost.

The Wilson Express Clamping System™

The Wilson Express Clamping System™ is the most exciting new development in press brake technology to take place in decades. It is a new, highly advanced series of punch holders that include a host of unique and innovative features designed to allow you to set up your press brake fast. Really fast!

- **Loading Punches Is A Snap**

With the Wilson Express Clamping System, 415mm long punches and individual pieces of sectionalized punches are loaded by simply placing them under the clamps and pushing them upward. There's no need to slide them in from the end of the machine. The spring loaded clamps capture the punch via the safety groove and hold it in place until the clamps are locked. To lock the clamps, you simply push a single removable lever upward.

- **Unloading Punches Is Fast And Simple**

To unlock the clamps, you simply pull down the locking lever. Small punch sections may then be removed by pushing inward on the top of the clamps. This opens the clamps, allowing the operator to pull the individual sections straight down. No need to slide them out the end of the machine. And, since the clamps are easily removed by hand, you can remove them from the punch holders that are not in use.

- **Dual Clamping Available**

For an additional cost you can have the dual clamping feature on your Wilson Express Clamping System. This feature allows you to load punches with the relief area facing forwards or towards the rear of the machine. And, both front and rear clamps are opened and closed simultaneously when the locking lever is actuated.

- **Uses Standard Tooling**

Unlike other so-called "quick clamping systems," the Wilson Express Clamping System is designed to use standard European (Promecam®) style press brake tooling with a safety groove. This allows you to use the same high quality Wilson tooling that you currently own. There is no need for a special type of tooling, and you won't have to re-purchase the system with every tool that you order.

- **No Hydraulics Required**

You also won't need an expensive hydraulic clamping system. The Wilson Express Clamping System is of a mechanical design and does not require hydraulics. This virtually eliminates maintenance and the possibility of hydraulic leaks as well as the possibility of punches being released in the event of a power failure.

- **Available For Your Press Brake**

The Wilson Express Clamping System is available for virtually all makes and models of press brakes—with and without adjustment wedges. This makes it easy to take advantage of the productivity gains and improved profitability that come with the Wilson Express Clamping System.

- **Call For A Free Demonstration**

Organising a free demonstration of this exciting technology is also quick and easy. Simply contact your local Wilson Tool® sales engineer or our sales desk on **0800 373748**, fax us on **0800 373758** or email us at sales@wilsontool.eu.com to arrange a free demonstration at your premises.



Express Clamping Systems for:



Amada® Z2 Style Press Brakes



American Press Brakes



Amada® Z1 and most European (Promecam®) Style Press Brakes

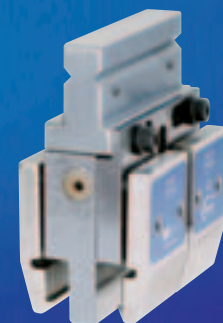

Trumpf Press Brakes



2V Dies.....	44	Large Radius Punches.....	19-20
2V Die Holders.....	48	Low Profile Quick Change 1V Dies.....	50
2V Die Rail And Clamp.....	48	Low Profile Sectionalized 2V Dies.....	47
2V Dies With Large Shoulder Radii.....	45	Narrow Punch Holders.....	64
3V Hemming Die.....	58	Quick Change 1V Die Holder And Wedge Block.....	53
30° Acute-Angle Punches.....	14-15	Quick Change 1V Dies.....	49
60° Acute-Angle Punches.....	16	Quick Change 2V Dies.....	40-41
75° Punches.....	17-18	Quick Change 2V Dies With Large Shoulder Radii.....	42
85° Gooseneck Punches.....	11	Quick Change 75° 1V Dies.....	52
88° Gooseneck Punches.....	8-9	Quick Change 75° 2V Dies.....	43
88° & 90° Gooseneck Punches With Thin Tip.....	10	Quick Change Back Gauge Stopper Pads.....	63
88° Narrow Punches.....	12	Quick Change Rail Style Flattening Die.....	58
88° Sash Punches.....	13	Quick Reference Chart.....	2-3
90° Gooseneck Punches.....	11	Rail Style Offset Tools.....	62
90° Narrow Punches.....	12	Sectionalized 2V Dies.....	45-46
90° Sash Punches.....	14	Sectionalized 2V Dies With Large Shoulder Radii.....	47
Acute-Angle Large 1V Dies.....	54	Side Gauge.....	63
Acute-Angle Quick Change 1V Dies.....	51	Stacking Punch Holder.....	66
Acute-Angle Quick Change 2V Dies.....	42	Stacking Rails.....	48
Air Bending Force Chart Metric.....	73	Standard 88° Punches.....	6
Bend Limit Graphs.....	22-39	Standard 90° Punches.....	6
Deep Punch Holder.....	65	Standard 88° & 90° Punches With Thin Tip.....	7
Dual Clamping Kits.....	66	Standard Die Lengths.....	1
European Die Holders.....	71	Standard Punch Lengths.....	1
European Punch Holders.....	67-70	Tooling Cabinet.....	72
Express Clamping System.....	4-5	Urethane Holders.....	60
Flattening Die.....	58	Urethane Pads.....	61
Flattening Punches.....	21	Urethane Rolls.....	72
Hemming Dies.....	59		
Large 1V Dies.....	55-57		
Large 1V Die Holder.....	57		

Prices and specifications subject to change without prior notice.

Terms and Conditions:

- Order:** Minimum order is £35.00.
- Credit:** All orders accepted are subject to the approval of our credit department. If you are a new account, please furnish us with a bank reference and three supplier references. A credit limit will be imposed on new accounts until credit has been established.
- Payment:** Terms are net 30 days.
- Cancellation:** In the event an order is cancelled, a charge will be made to cover labour, material and overheads.
- Returned Material:** A handling charge of 25% is made on all standard parts returned for credit. Written permission and shipping instructions must be obtained before the return of any material. Special tooling cannot be returned.
- Claims:** All claims for shortages must be made within 10 days of invoice date.

Standard Punch Lengths

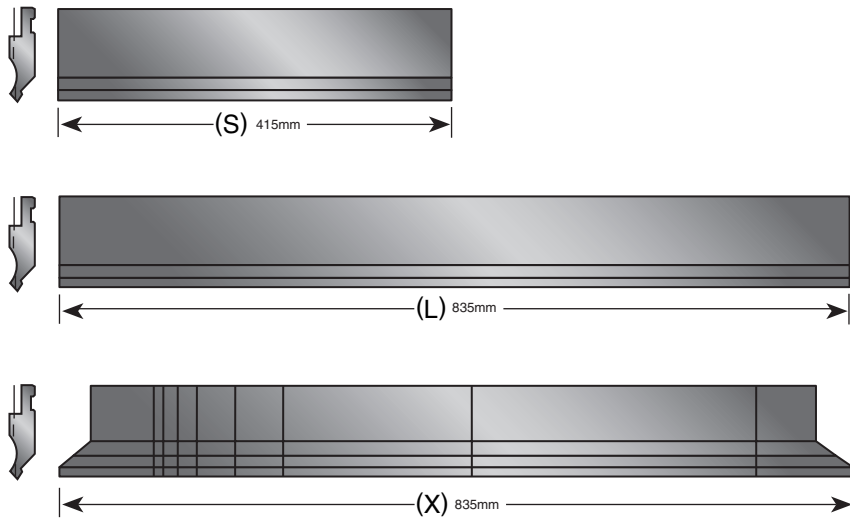

FEATURES:

1. Most tools can be easily loaded by a single operator.
2. Easy to store.
3. All sectionalized tools come pre-cut in nine different pieces.
4. Most sectionalized punches include two ear pieces (horns).
5. NITREX™ (HRC-60) is available for every punch in the tooling line.
6. Special Tooling available. Please contact the sales desk.

SECTION WIDTHS:

100mm **LEFT EAR** / 100mm **RIGHT EAR** / 10mm / 15mm / 20mm / 40mm / 50mm / 200mm / 300mm

Note: Special lengths are available at additional cost.

Standard Die Lengths

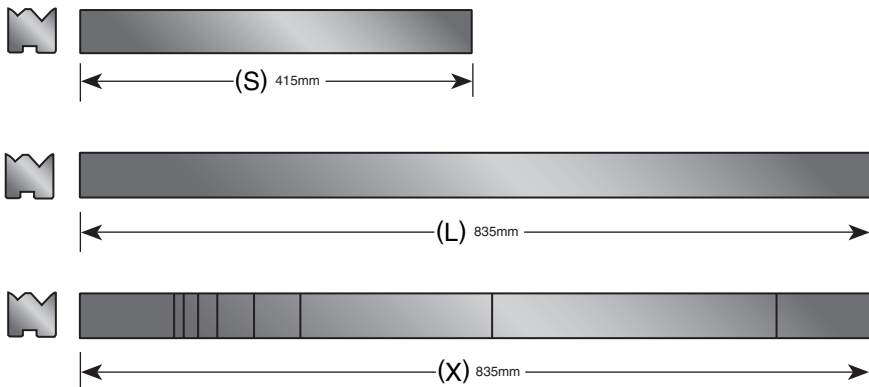

FEATURES:

1. Most tools can be easily loaded by a single operator.
2. Easy to store.
3. All sectionalized tools come pre-cut in nine different pieces.
4. Most dies are NITREX enhanced (HRC-60) as standard.
5. Special Tooling available. Please contact the sales desk.

SECTION WIDTHS:

100mm / 100mm / 10mm / 15mm / 20mm / 40mm / 50mm / 200mm / 300mm

Note: Special lengths are available at additional cost.

Tel: +44 (0) 1793 831818
Email: sales@wilsontool.eu.com

Free Phone:
Free Fax:

0800 373748
0800 373758

Tel Free:
Fax Free:

1-800 70 90 09 Ireland
1-800 53 55 38 Ireland



**90 DEGREE BENDING
(0.4 - 3.4mm)**

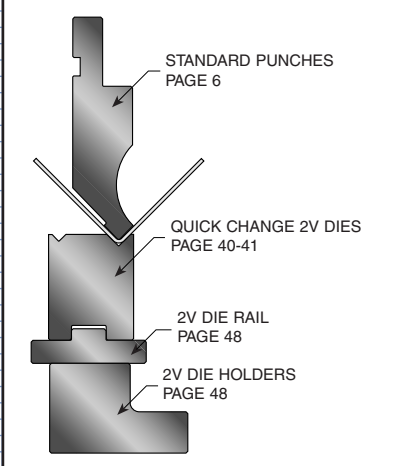

**90 DEGREE BENDING
WITH THIN TIP PUNCH**

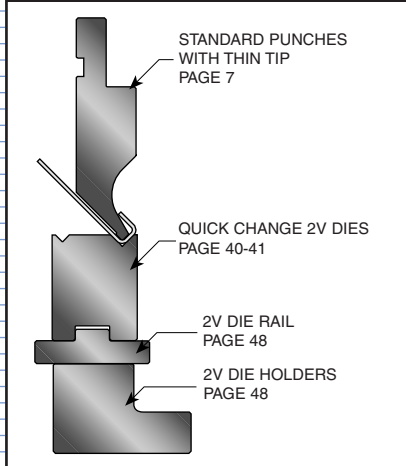

**90 DEGREE BENDING
WITH NARROW PUNCH**

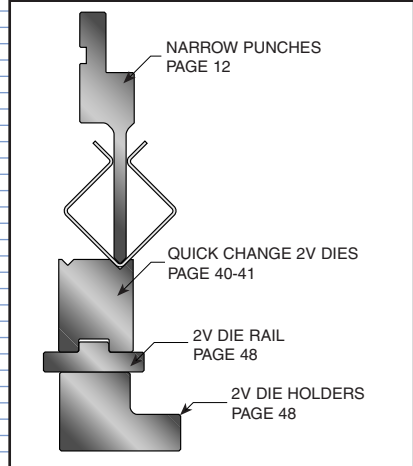

**90 DEGREE BENDING WITH
THIN TIP GOOSENECK PUNCH**

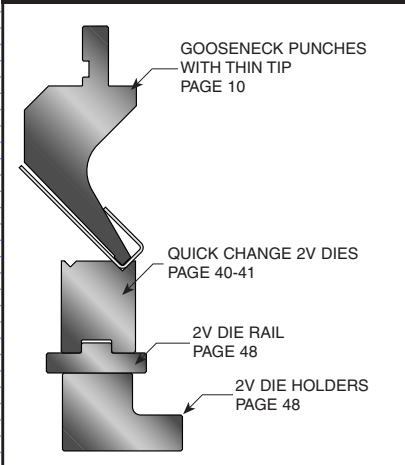

**90 DEGREE BENDING WITH
GOOSENECK PUNCH**

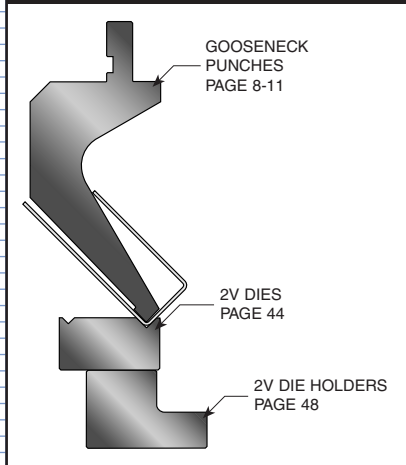

**90 DEGREE BENDING
(SASH)**

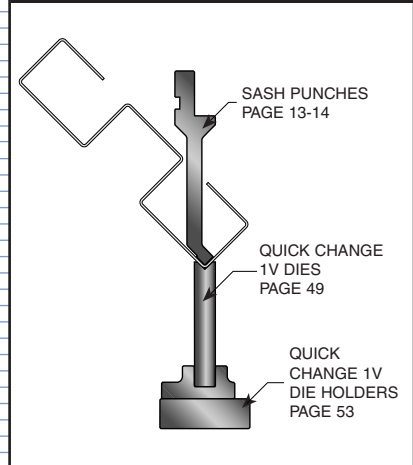

**LARGE RADIUS BENDING
(WITH URETHANE DIE)**

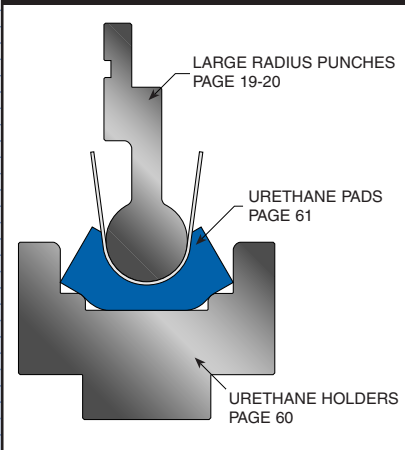

**90 DEGREE BENDING
(9.5 - 12.7mm)**

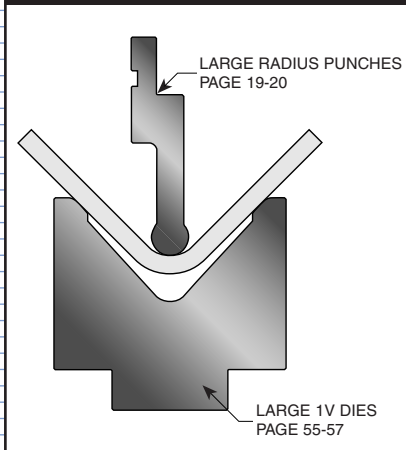

**LARGE
RADIUS BENDING**

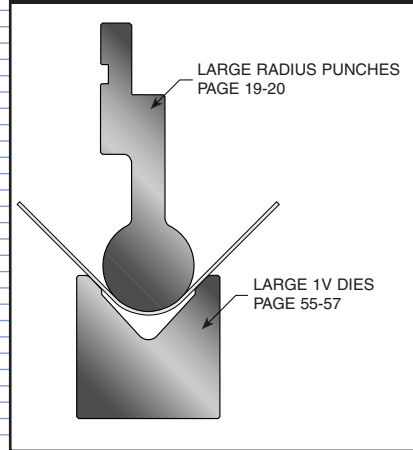

**ACUTE-ANGLE BENDING
(2.7 - 4.9mm)**

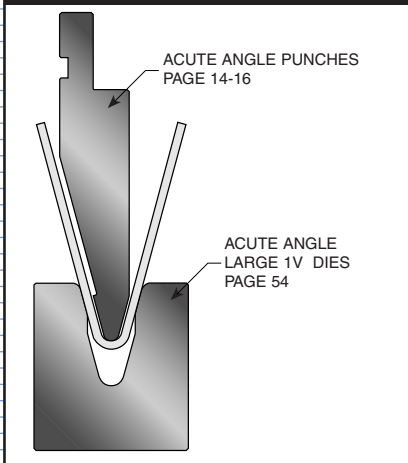

**90 DEGREE BENDING
(3.8 - 9.5mm)**

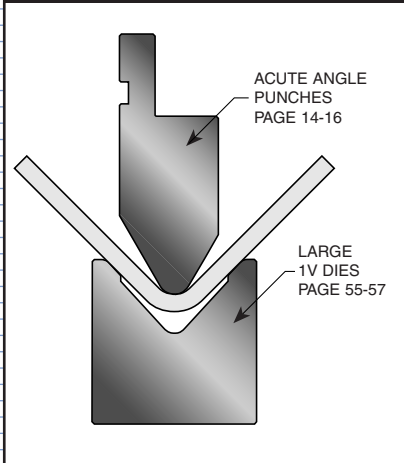

**HEMMING (2 STAGE)
(0.4 - 1.9mm)**

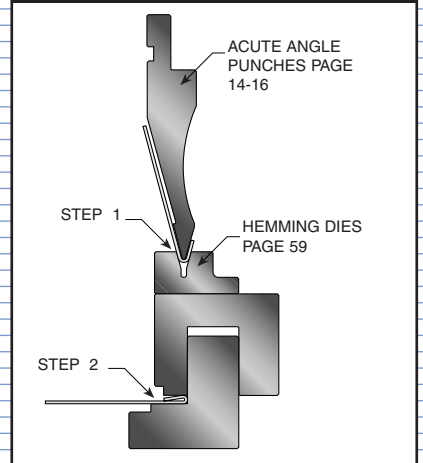

**ACUTE-ANGLE BENDING
(0.4 - 1.9mm)**

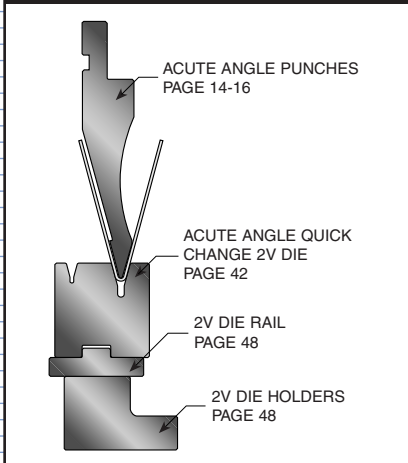

DEEP BOX BENDING

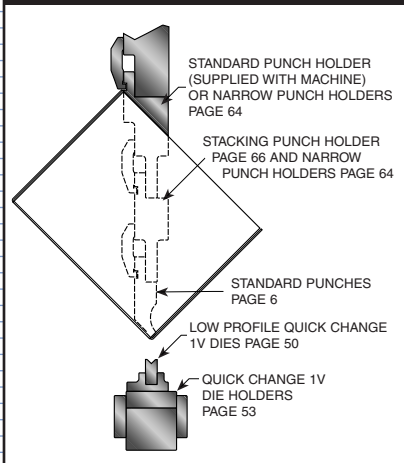

DEEP PUNCH HOLDER

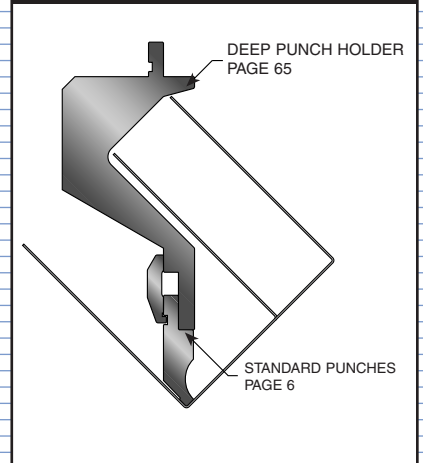

**HEMMING
(0.4 - 1.5mm)**

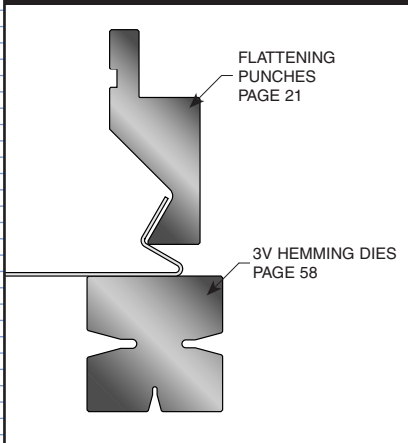

**HEMMING
(0.4 - 3.0mm)**

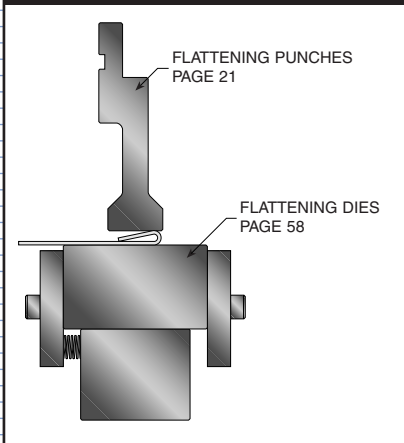

**OFFSET BENDING
(0.4 - 1.5mm)**

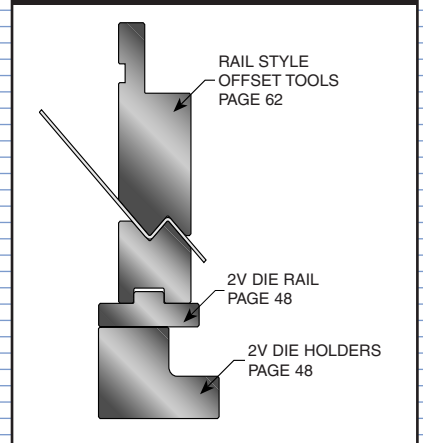

Wilson Express Clamping System™



43815 (replaces 43015)
For Conventional Press Brakes
With Wedge



43817 (replaces 43017)
Z1 Series
With Wedge



43031
For Mitsubishi Toyokoki
HYB Series Press Brakes
-Dual Clamping Included



43033
For Mitsubishi Toyokoki
APB Series Press Brakes
-Dual Clamping Included



*Note: Other Punch Holders Shown On Pages 64–70

Wilson Express Clamping System™



43818 (replaces 43018)
Z2 Series With Wedge



43819 (replaces 43019)
For Trumpf Press Brakes With Wedge

*Note: Other Punch Holders Shown On Pages 64–70

Express Clamp Torque Wrench Kit

Cat. No. 08002, 08003, 43726, 06793, 06795,



CATALOGUE NUMBER	COMPONENT	PIECE PRICE	KIT PRICE
08002	Complete Kit		
08003	Case		1/Kit =
43726	Pivots		2/Kits =
06793	Wrench		1/Kit =
06795	Hex Tips		2/Kits =



Tel: +44 (0) 1793 831818
Email: sales@wilsontool.eu.com

Free Phone:
Free Fax:

0800 373748
0800 373758

Tel Free:
Fax Free:

1-800 70 90 09 Ireland
1-800 53 55 38 Ireland



Standard 88° Punches

Cat. No. E40002, E40006, E40008, E40015, E40023, 4E0030

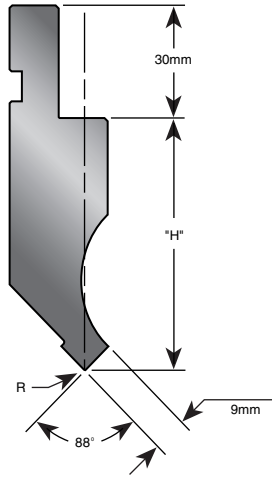

Part No. E40002

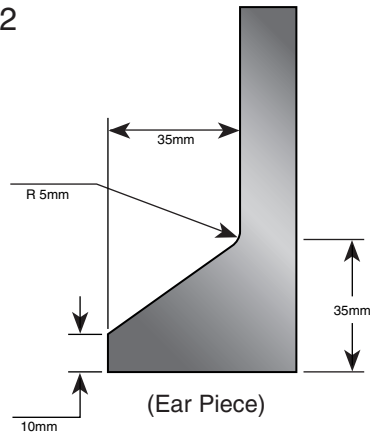

CATALOGUE NUMBER	R mm	MAX. TON per metre (L & S)	MAX. TON per metre (X)	"H"	L 835mm	S 415mm	X SECTIONALIZED
E40002	0.2	100	47	66.9			
E40006	0.6	100	47	66.4			
E40008	0.8	100	47	66.6			
E40015	1.5	100	47	66.3			
E40023	2.3	100	47	66.0			
E40030	3.0	100	47	65.7			

*Note: Punch tip modifications and punch relief available at additional cost. Contact the sales desk for prices and lead times.
Nitrex™(HRC-60) available for every punch in the tooling range at additional cost.

Standard 90° Punches

Cat. No. E40102, E40108, E40115, E40123, E40130

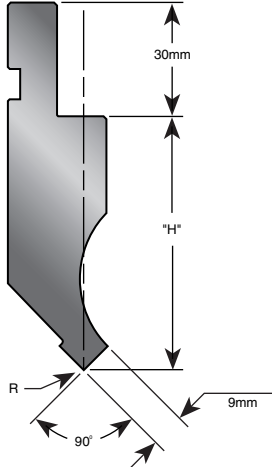

Part No. E40102

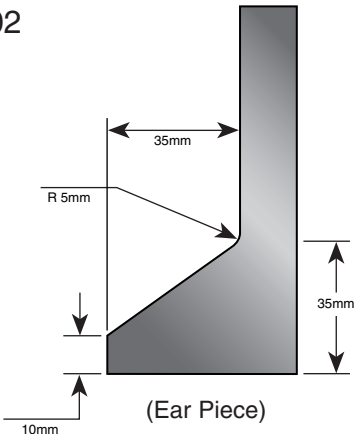

CATALOGUE NUMBER	R mm	MAX. TON per metre (L & S)	MAX. TON per metre (X)	"H"	L 835mm	S 415mm	X SECTIONALIZED
E40102	0.2	100	47	66.9			
E40108	0.8	100	47	66.7			
E40115	1.5	100	47	66.4			
E40123	2.3	100	47	66.0			
E40130	3.0	100	47	65.7			

*Note: Punch tip modifications and punch relief available at an additional cost. Contact the application sales desk for pricing and lead times.
Nitrex™(HRC-60) available for every punch and die in the tooling line.

Standard 90° Punches With Thin Tip

Cat. No. E40202 and E40206

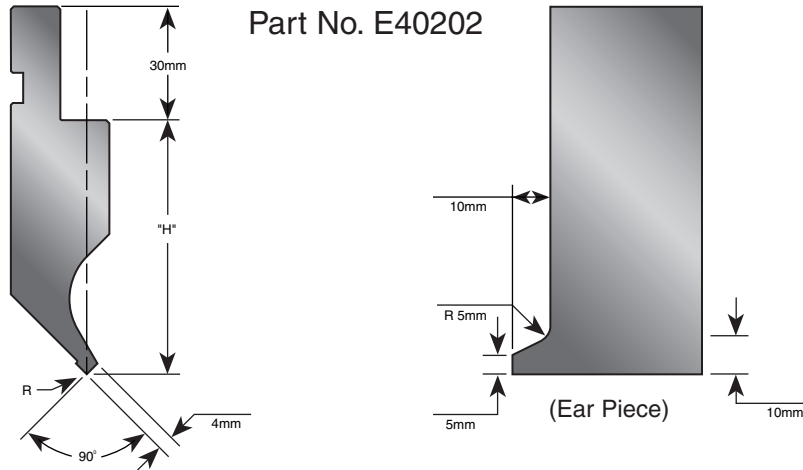

CATALOGUE NUMBER	R mm	MAX. TON per metre (L & S)	MAX. TON per metre (X)	"H"	L 835mm	S 415mm	X SECTIONALIZED
E40202	0.2	20	10	66.9			
E40206	0.6	20	10	66.4			

*Note: Punch tip modifications and punch relief available at additional cost. Contact the sales desk for prices and lead times.
Nitrex™ (HRC-60) available for every punch in the tooling range at additional cost.

Standard 88° Punches With Thin Tip

Cat. No. E40212

Part No. E40212

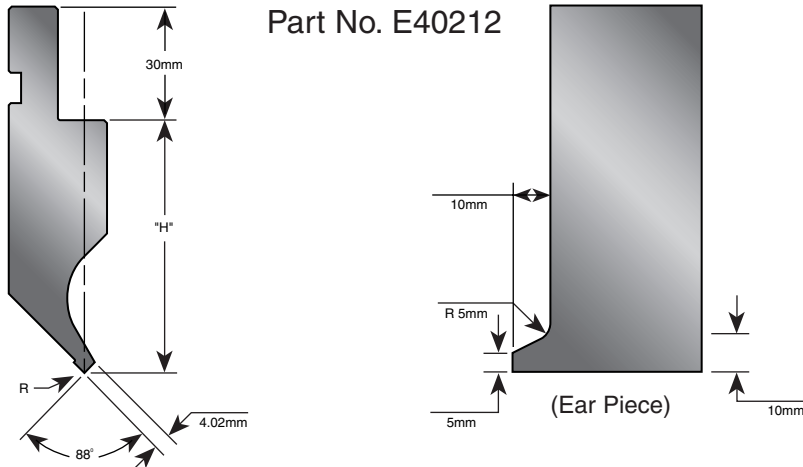

CATALOGUE NUMBER	R mm	MAX. TON per metre (L & S)	MAX. TON per metre (X)	"H"	L 835mm	S 415mm	X SECTIONALIZED
E40212	0.2	20	10	66.9			

*Note: Punch tip modifications and punch relief available at an additional cost. Contact the application sales desk for pricing and lead times.
Nitrex™ (HRC-60) available for every punch and die in the tooling line.

Tel: +44 (0) 1793 831818
Email: sales@wilsontool.eu.com

Free Phone:
Free Fax:

0800 373748
0800 373758

Tel Free:
Fax Free:

1-800 70 90 09 Ireland
1-800 53 55 38 Ireland

88° Gooseneck Punches

Cat. No. E40302 - E40630

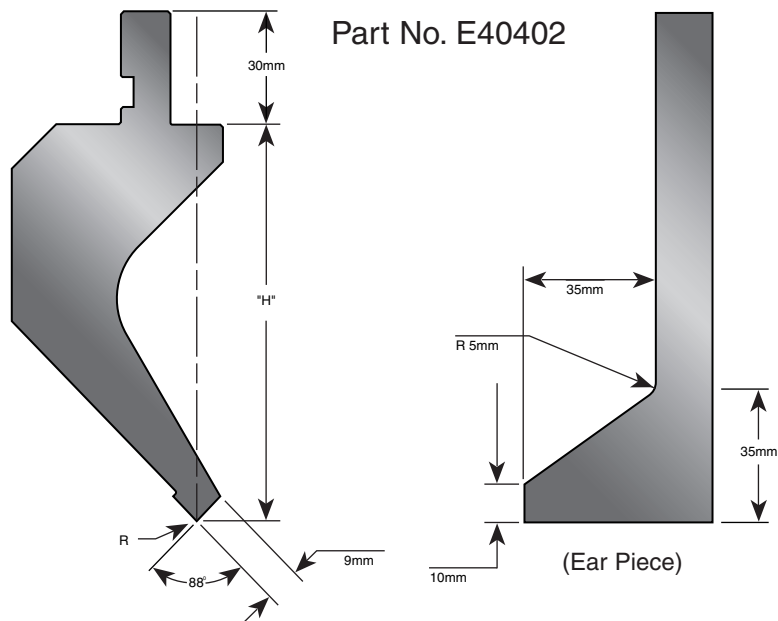
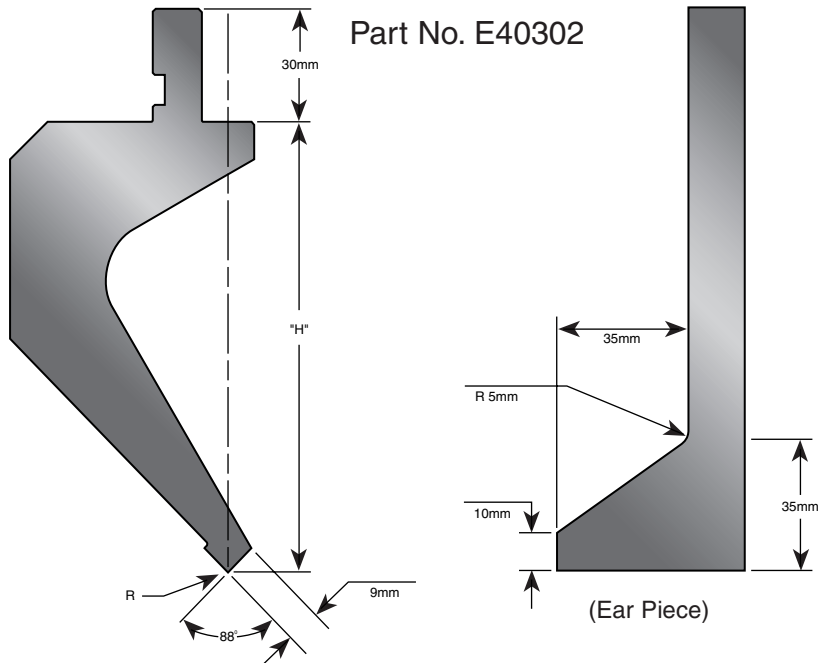

*Note: Punch tip modifications and punch relief available at additional cost. Contact the sales desk for prices and lead times.
Nitrex™ (HRC-60) available for every punch in the tooling range at additional cost.

88° Gooseneck Punches

Cat. No. E40302 - E40630

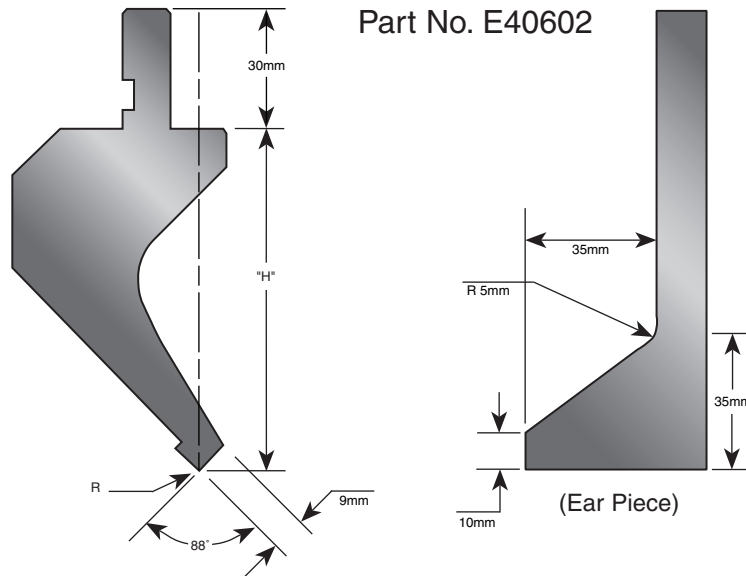

CATALOGUE NUMBER	R mm	MAX. TON per metre (L & S)	MAX. TON per metre (X)	"H"	L 835mm	S 415mm	X SECTIONALIZED
E40302	0.2	50	50	119.9			
E40306	0.6	50	50	119.4			
E40308	0.8	50	50	119.7			
E40402	0.2	50	47	104.9			
E40406	0.6	50	47	104.4			
E40408	0.8	50	47	104.6			
E40415	1.5	50	47	104.3			
E40430	3.0	50	47	103.7			
E40602	0.2	70	47	89.9			
E40606	0.6	70	47	89.4			
E40608	0.8	70	47	89.6			
E40615	1.5	70	47	89.3			
E40630	3.0	70	47	88.7			

*Note: Punch tip modifications and punch relief available at additional cost. Contact the sales desk for prices and lead times.
Nitrex™(HRC-60) available for every punch in the tooling range at additional cost.

Tel: +44 (0) 1793 831818
Email: sales@wilsontool.eu.com

Free Phone:
Free Fax:

0800 373748
0800 373758

Tel Free:
Fax Free:

1-800 70 90 09 Ireland
1-800 53 55 38 Ireland

88° Gooseneck Punches With Thin Tip

Cat. No. E40702, E40706, E40708

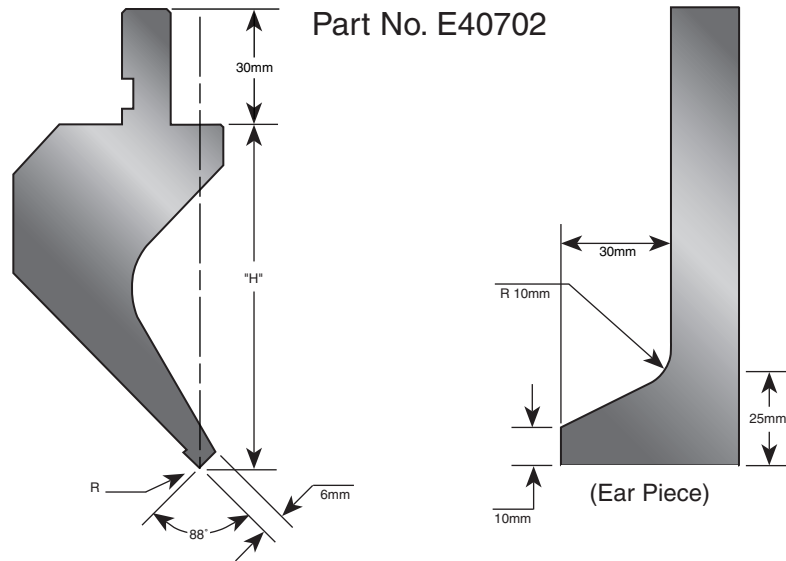

CATALOGUE NUMBER	R mm	MAX. TON per metre (L & S)	MAX. TON per metre (X)	"H"	L 835mm	S 415mm	X SECTIONALIZED
E40702	0.2	50	30	89.9			
E40706	0.6	50	30	89.4			
E40708	0.8	50	30	89.6			

*Note: Punch tip modifications and punch relief available at additional cost. Contact the sales desk for prices and lead times.
Nitrex™ (HRC-60) available for every punch in the tooling range at additional cost.

90° Gooseneck Punches With Thin Tip

Cat. No. E40712 and E40718

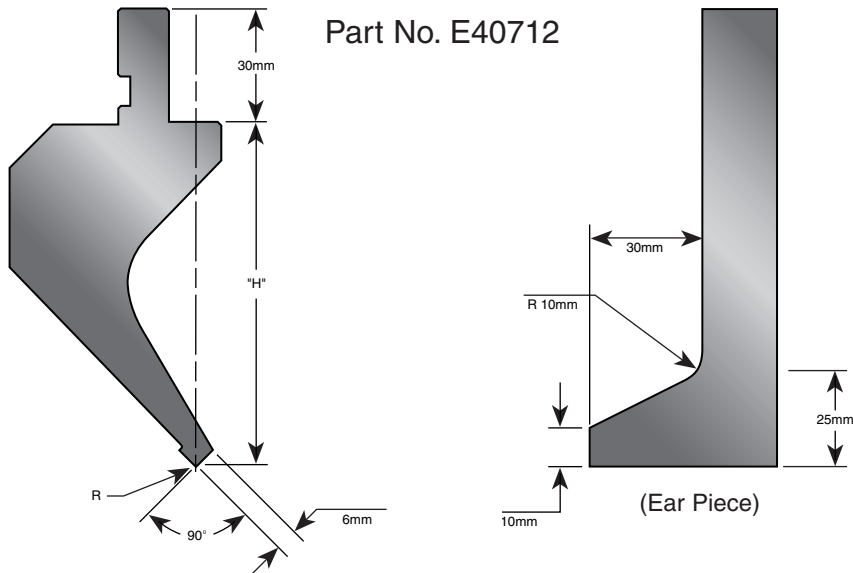

CATALOGUE NUMBER	R mm	MAX. TON per metre (L & S)	MAX. TON per metre (X)	"H"	L 835mm	S 415mm	X SECTIONALIZED
E40712	0.2	50	30	89.9			
E40718	0.8	50	30	89.7			

*Note: Punch tip modifications and punch relief available at additional cost. Contact the sales desk for prices and lead times.
Nitrex™ (HRC-60) available for every punch in the tooling range at additional cost.

90° Gooseneck Punches

Cat. No. E40502

Part No. E40502

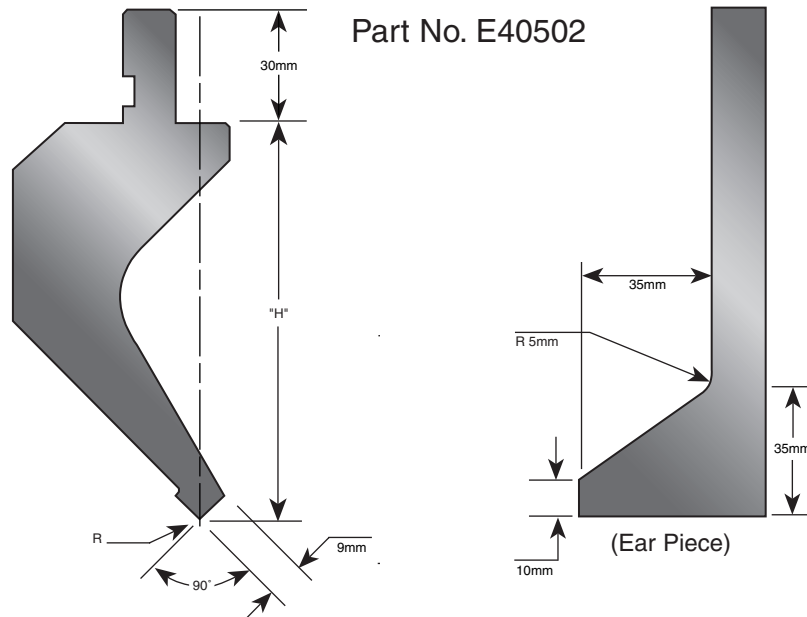

CATALOGUE NUMBER	R mm	MAX. TON per metre (L & S)	MAX. TON per metre (X)	"H"	L 835mm	S 415mm	X SECTIONALIZED
E40502	0.2	50	47	104.9			

*Note: Punch tip modifications and punch relief available at additional cost. Contact the sales desk for prices and lead times.
Nitrex™ (HRC-60) available for every punch in the tooling range at additional cost.

85° Gooseneck Punches

Cat. No. E44540 and E44560

Part No. E40402

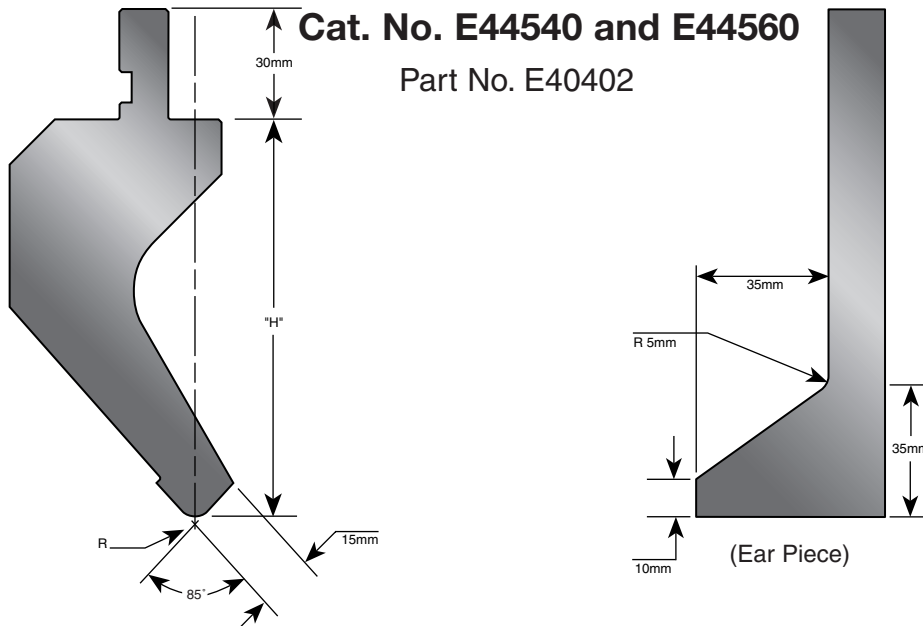

CATALOGUE NUMBER	R mm	MAX. TON per metre (L & S)	MAX. TON per metre (X)	"H"	L 835mm	S 415mm	X SECTIONALIZED
E44540	4.8	100	47	105.0			
E44560	6.4	100	47	104.3			

*Note: Punch tip modifications and punch relief available at additional cost. Contact the sales desk for prices and lead times.
Nitrex™ (HRC-60) available for every punch in the tooling range at additional cost.

Tel: +44 (0) 1793 831818
Email: sales@wilsontool.eu.com

Free Phone:
Free Fax:

0800 373748
0800 373758

Tel Free:
Fax Free:

1-800 70 90 09 Ireland
1-800 53 55 38 Ireland

88° Narrow Punches

Cat. No. E40802 and E40806

Part No. E40802

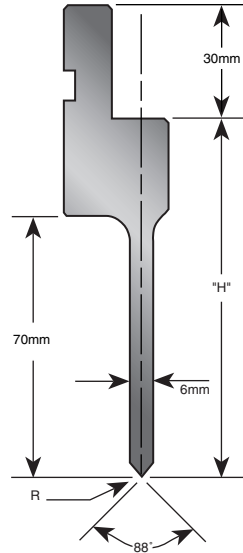

CATALOGUE NUMBER	R mm	MAX. TON per metre (L & S)	MAX. TON per metre (X)	"H"	L 835mm	S 415mm	X SECTIONALIZED
E40802	0.2	50	50	95.0			
E40806	0.6	50	50	94.5			

*Note: Sectionalized version does not include ear pieces (horns). Ear pieces (horns) available at additional cost.

Punch tip modifications and punch relief available at additional cost. Contact the sales desk for pricing and lead times.

Nitrex™ (HRC-60) available for every punch in the tooling range at additional cost.

90° Narrow Punches

Cat. No. E40902

Part No. E40902

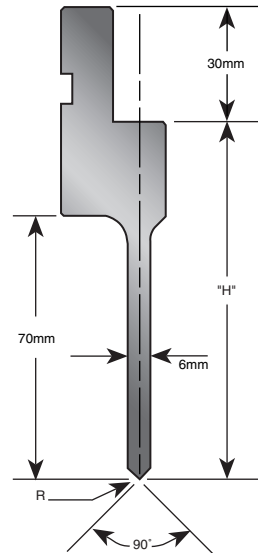

CATALOGUE NUMBER	R mm	MAX. TON per metre	"H"	L 835mm	S 415mm	X SECTIONALIZED
E40902	0.2	50	95.0			

*Note: Sectionalized version does not include ear pieces (horns). Ear pieces (horns) available at additional cost.

Punch tip modifications and punch relief available at additional cost. Contact the sales desk for pricing and lead times.

Nitrex™ (HRC-60) available for every punch in the tooling range at additional cost.

88° Sash Punches

Cat. No. E41002, E41006, E41102, E41106

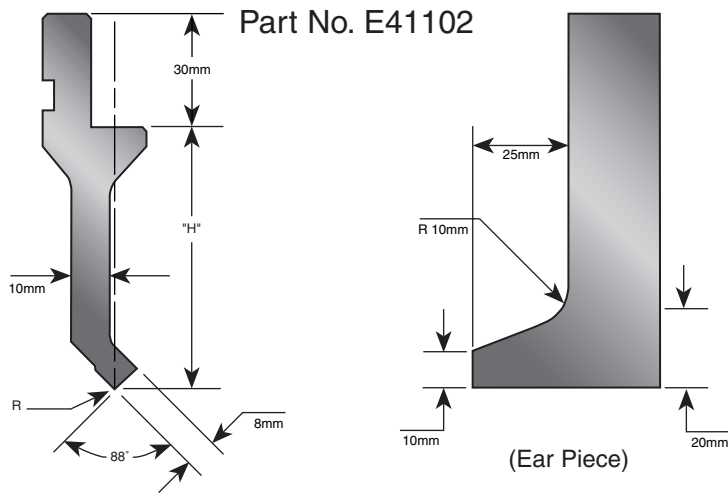
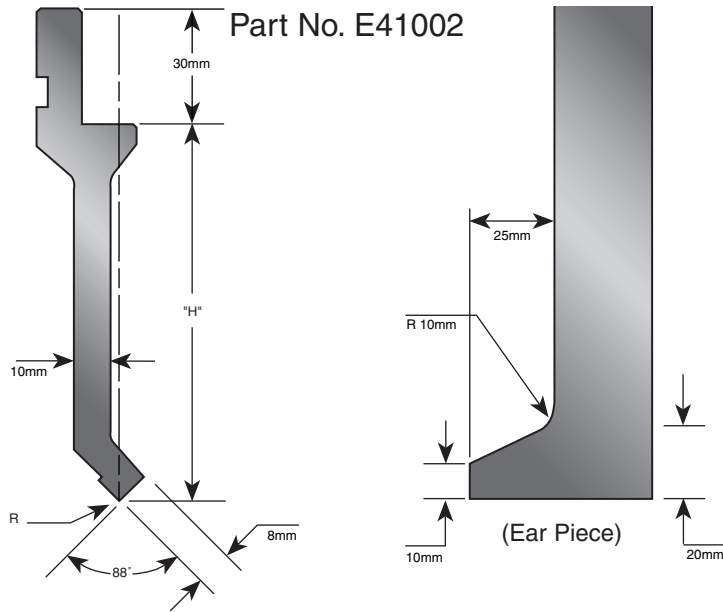

CATALOGUE NUMBER	R mm	MAX. TON per metre (L & S)	MAX. TON per metre (X)	"H"	L 835mm	S 415mm	X SECTIONALIZED
E41002	0.2	30	30	99.9			
E41006	0.6	30	30	99.4			
E41102	0.2	30	30	69.9			
E41106	0.6	30	30	69.4			

*Note: Punch tip modifications and punch relief available at additional cost. Contact the sales desk for prices and lead times.

Nitrex™(HRC-60) available for every punch in the tooling range at additional cost.

Tel: +44 (0) 1793 831818
Email: sales@wilsontool.eu.com

Free Phone:
Free Fax:

0800 373748
0800 373758

Tel Free:
Fax Free:

1-800 70 90 09 Ireland
1-800 53 55 38 Ireland



90° Sash Punches

Cat. No. E41202

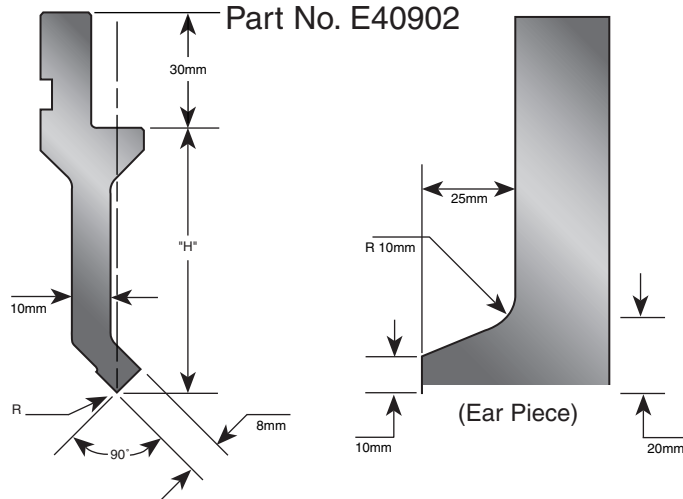

CATALOGUE NUMBER	R mm	MAX. TON per metre (L & S)	MAX. TON per metre (X)	"H"	L 835mm	S 415mm	X SECTIONALIZED
E41202	0.2	30	30	69.9			

*Note: Punch tip modifications and punch relief available at additional cost. Contact the sales desk for prices and lead times.

Nitrex™ (HRC-60) available for every punch in the tooling range at additional cost.

30° Acute-Angle Punches

Cat. No. E41908

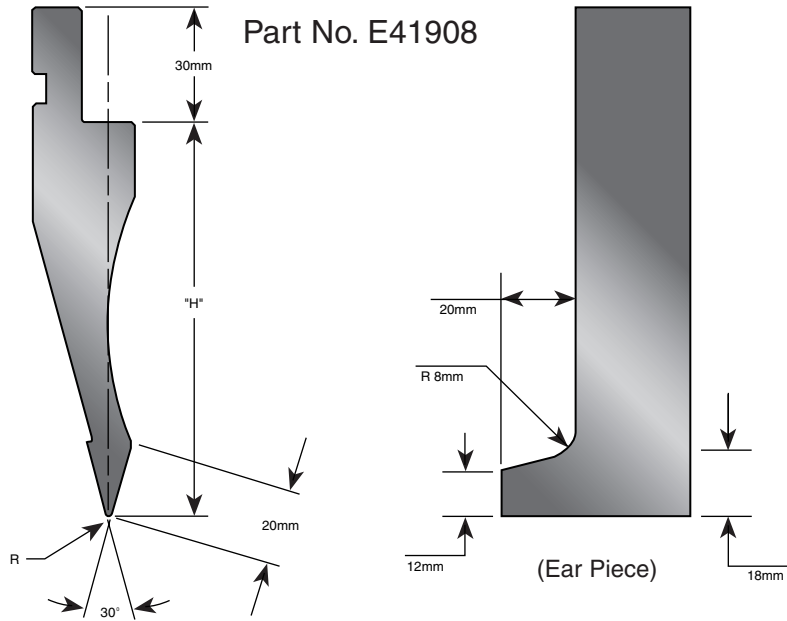

CATALOGUE NUMBER	R mm	MAX. TON per metre (L & S)	MAX. TON per metre (X)	"H"	L 835mm	S 415mm	X SECTIONALIZED
E41908	0.8	100	20	104.0			

*Note: Punch tip modifications and punch relief available at additional cost. Contact the sales desk for prices and lead times.

Nitrex™ (HRC-60) available for every punch in the tooling range at additional cost.

30° Acute-Angle Punches

Cat. No. E41315 and E41330

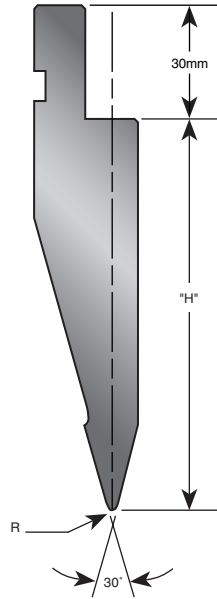

CATALOGUE NUMBER	R mm	MAX. TON per metre (L & S)	MAX. TON per metre (X)	"H"	L 835mm	S 415mm	X SECTIONALIZED
E41315	1.5	100	100	102.0			
E41330	3.0	100	100	97.7			

*Note: Sectionalized version does not include ear pieces (horns). Ear pieces (horns) available at additional cost.

Punch tip modifications and punch relief available at additional cost. Contact the sales desk for prices and lead times.

Nitrex™ (HRC-60) available for every punch in the tooling range at additional cost.

30° Acute-Angle Punches

Cat. No. E42610

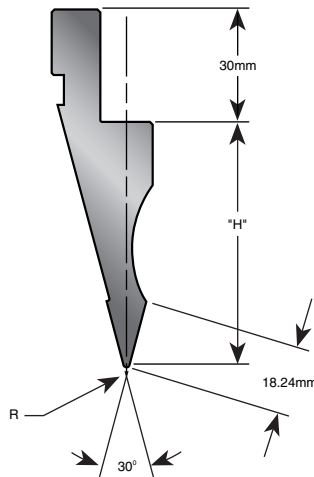

CATALOGUE NUMBER	R mm	MAX. TON per metre (L & S)	MAX. TON per metre (X)	"H"	L 835mm	S 415mm	X SECTIONALIZED
E42610	0.8	100	100	65.5			

*Note: Sectionalized version does not include ear pieces (horns). Ear pieces (horns) available at additional cost.

Punch tip modifications and punch relief available at additional cost. Contact the sales desk for prices and lead times.

Nitrex™ (HRC-60) available for every punch in the tooling range at additional cost.

Tel: +44 (0) 1793 831818
Email: sales@wilsontool.eu.com

Free Phone:
Free Fax:

0800 373748
0800 373758

Tel Free:
Fax Free:

1-800 70 90 09 Ireland
1-800 53 55 38 Ireland



60° Acute-Angle Punches

Cat. No. E41440 and E41460

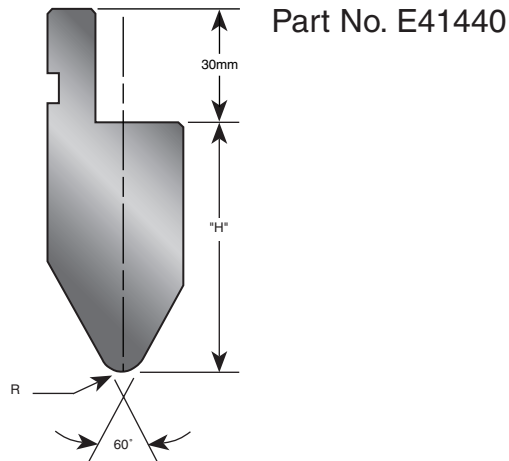

CATALOGUE NUMBER	R mm	MAX. TON per metre (L & S)	"H"	L 835mm	S 415mm	X SECTIONALIZED
E41440	4.8	100	66.2			
E41460	6.0	100	65.0			

*Note: Sectionalized version does not include ear pieces (horns). Ear pieces (horns) available at additional cost.

Punch tip modifications and punch relief available at additional cost. Contact the sales desk for prices and lead times.

Nitrex™ (HRC-60) available for every punch in the tooling range at additional cost.

75° Punches

Cat. No. E44000 - E44030

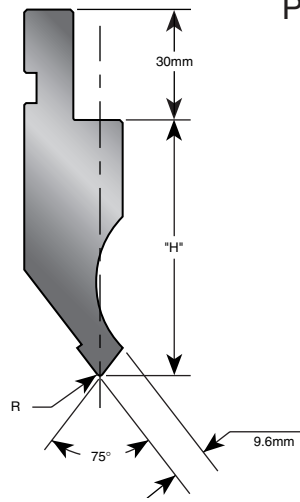

Part No. E44000

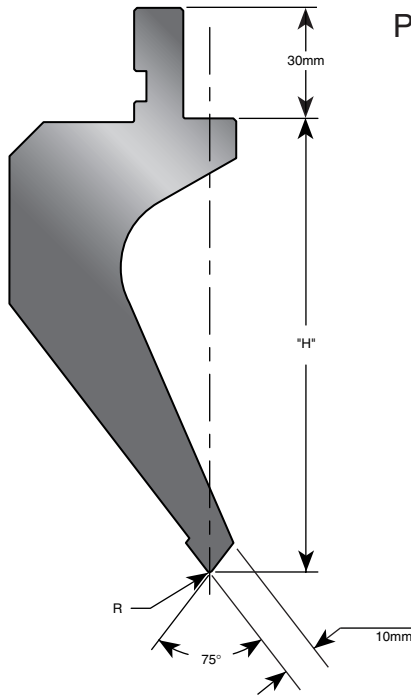
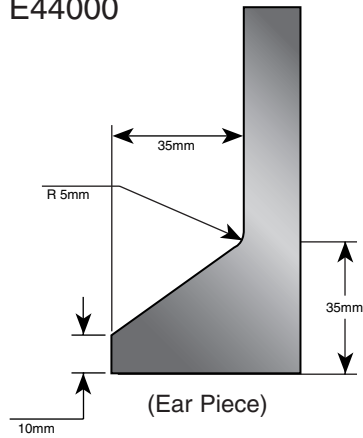

Part No. E44030

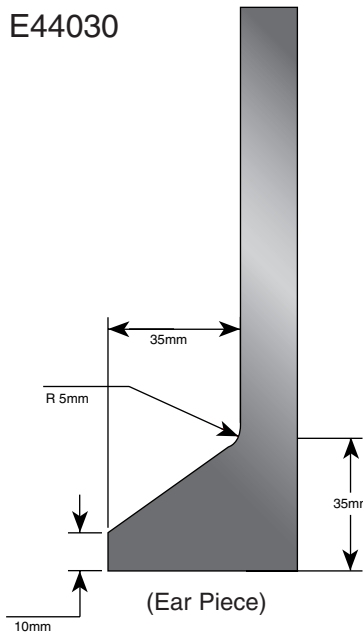

CATALOGUE NUMBER	R mm	MAX. TON per metre (L & S)	MAX. TON per metre (X)	"H"	L 835mm	S 415mm	X SECTIONALIZED
E44000	0.8	100	47	67.6			
E44001	1.5	100	47	67.2			
E44003	3.0	100	47	66.2			
E44030	0.8	50	50	120.0			
E44031	1.5	50	50	119.5			
E44033	3.0	50	50	118.6			

*Note: Punch tip modifications and punch relief available at additional cost. Contact the sales desk for prices and lead times.

Nitrex™ (HRC-60) available for every punch in the tooling range at additional cost.

Tel: +44 (0) 1793 831818
Email: sales@wilsontool.eu.com

Free Phone: 0800 373748
Free Fax: 0800 373758

Tel Free: 1-800 70 90 09 Ireland
Fax Free: 1-800 53 55 38 Ireland



75° Punches

Cat. No. E44020 - E44040

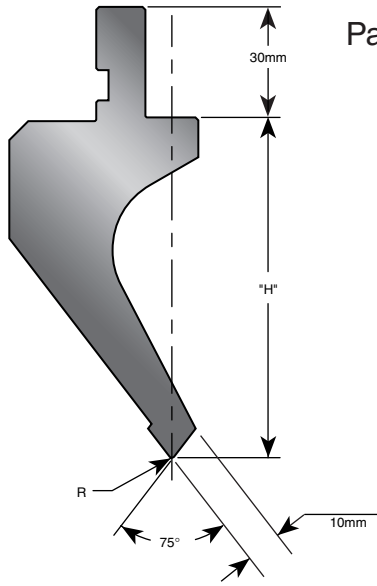

Part No. E44020

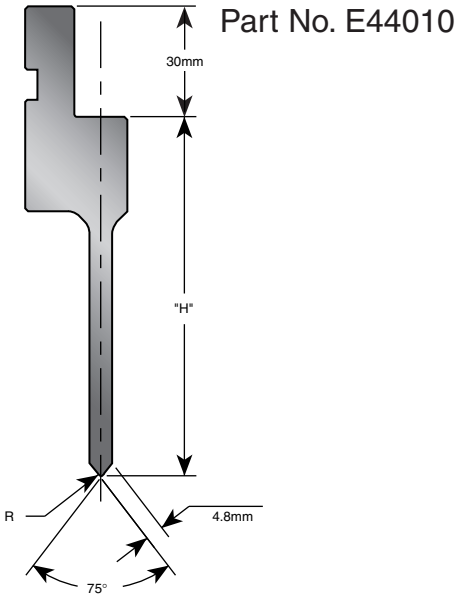
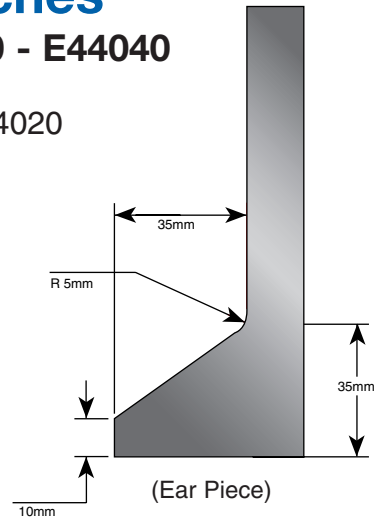

Part No. E44010

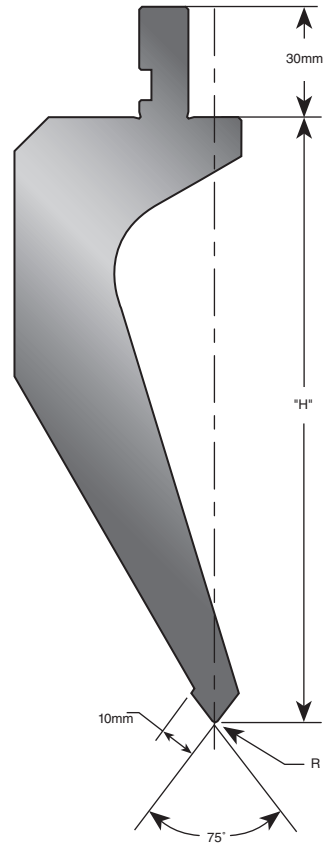

Part No. E44040

*Nitrex™ is standard on Cat. No. 44040 only

CATALOGUE NUMBER	R mm	MAX. TON per metre (L & S)	MAX. TON per metre (X)	"H"	L 835mm	S 415mm	X SECTIONALIZED
E44020	0.8	70	47	90.0			
E44021	1.5	70	47	89.5			
E44023	3.0	70	47	88.6			
E44010	0.8	50	50	95.0			
E44011	1.5	50	50	94.5			
E44013	3.0	50	50	93.6			
*E44040	0.8	50	47	160.0	Call for pricing and lead time.		

*Note: Sectionalized version does not include ear pieces (horns). Ear pieces (horns) available at additional cost. (E44010 only)
 Punch tip modifications and punch relief available at additional cost. Contact the sales desk for prices and lead times.
 Nitrex™ (HRC-60) available for every punch in the tooling range at additional cost.

Large Radius Punches

Cat. No. E41709 - E41719

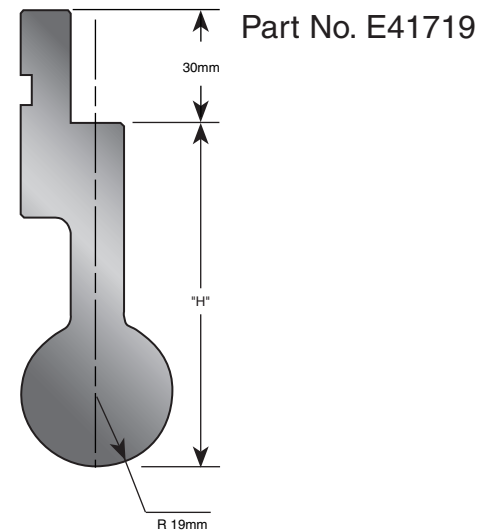
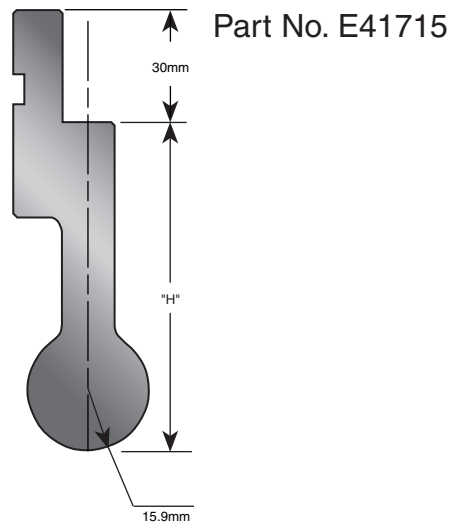
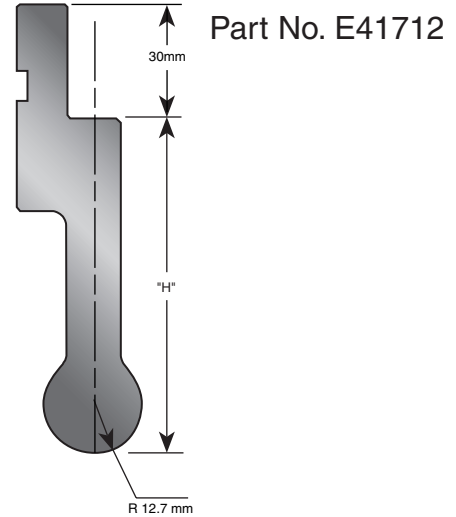
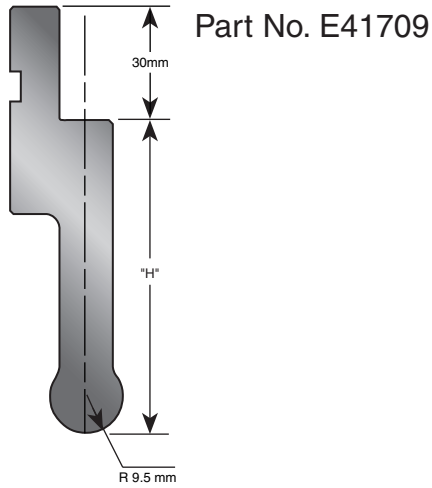

CATALOGUE NUMBER	MAX. TON per metre	"H"	L 835mm	S 415mm	X SECTIONALIZED
E41709	100	83.0			
E41712	100	89.0			
E41715	100	87.0			
E41719	100	91.0			

*Note: Sectionalized version does not include ear pieces (horns). Ear pieces (horns) available at additional cost.

Nitrex™ (HRC-60) available for every punch in the tooling range at additional cost.

Additional radii available, please contact the sales desk.

Tel: +44 (0) 1793 831818
Email: sales@wilsontool.eu.com

Free Phone:
Free Fax:

0800 373748
0800 373758

Tel Free:
Fax Free:

1-800 70 90 09 Ireland
1-800 53 55 38 Ireland

Large Radius Punches

Cat. No. E41722 and E41725

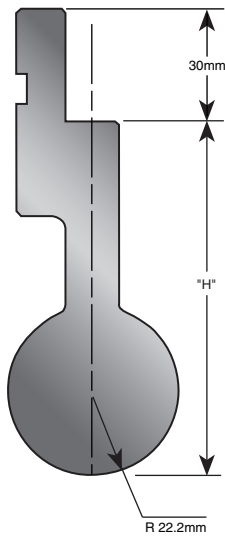

Part No. E41722

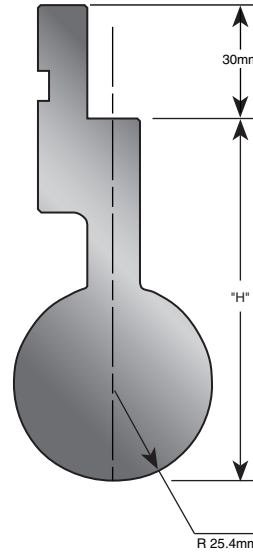

Part No. E41725

CATALOGUE NUMBER	MAX. TON per metre	"H"	L 835mm	S 415mm	X SECTIONALIZED
E41722	100	94.0			
E41725	100	96.0			

*Note: Sectionalized version does not include ear pieces (horns). Ear pieces (horns) available at an additional cost.

Nitrex™(HRC-60) available for every punch and die in the tooling line.

Additional radii available, please contact our application sales desk.

Flattening Punches

Cat. No. E41523 and E41630

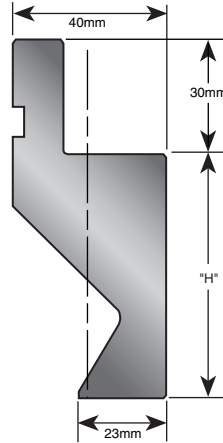

Part No. E41523

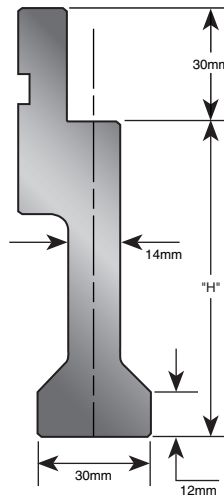

Part No. E41630

CATALOGUE NUMBER	MAX. TON per metre	"H"	L 835mm	S 415mm
E41523	100	65.0		
E41630	100	84.0		

*Note: Nitrex™(HRC-60) available for every punch in the tooling range at additional cost.

Tel: +44 (0) 1793 831818
Email: sales@wilsontool.eu.com

Free Phone: 0800 373748
Free Fax: 0800 373758

Tel Free: 1-800 70 90 09 Ireland
Fax Free: 1-800 53 55 38 Ireland



Bend Limit Graph

CATALOGUE NO. E40002, E40008, E40015, E40023, E40030,
E40102, E40108, E40115, E40123, E40130

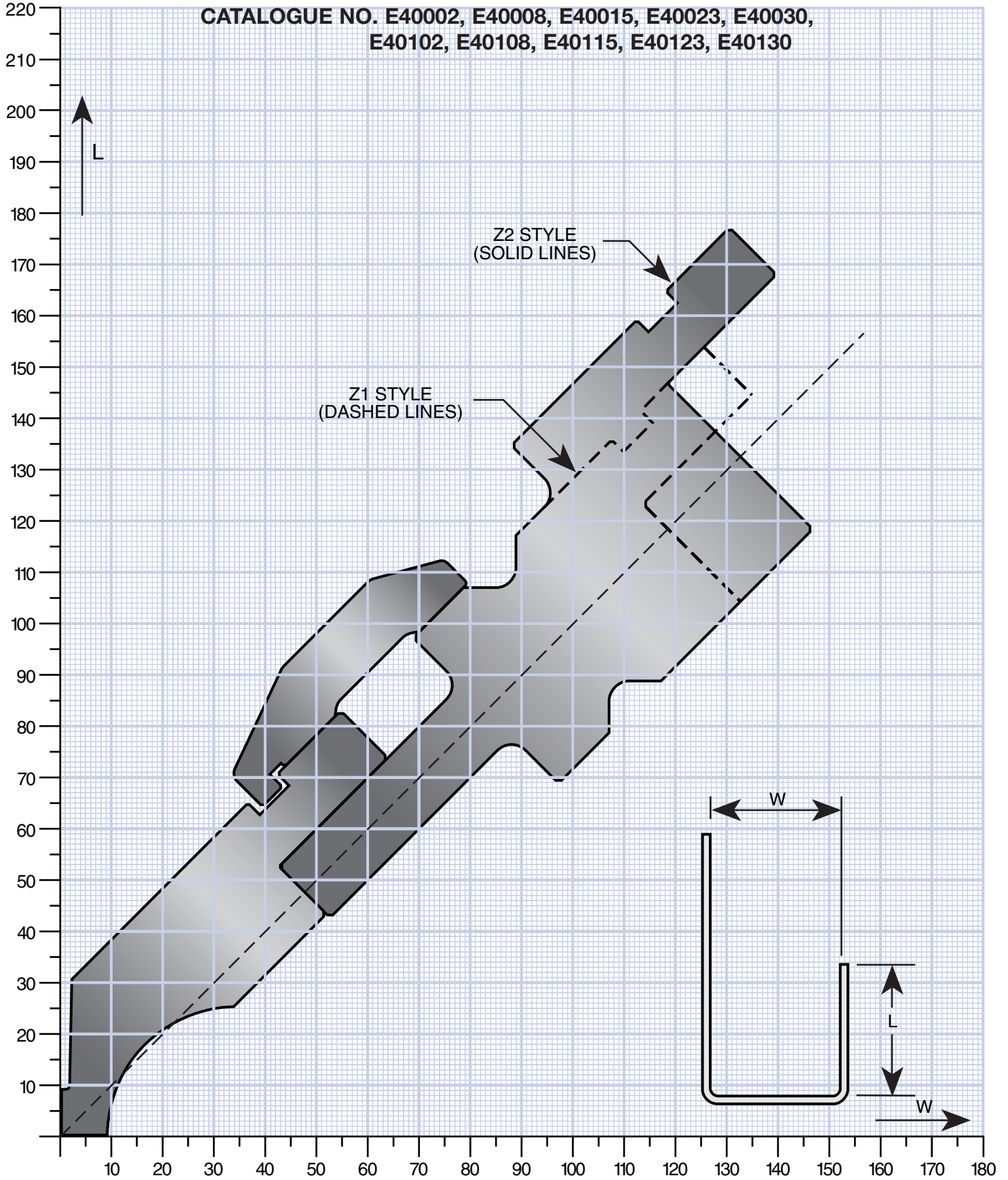

Bend Limit Graph

CATALOGUE NO. E40202, E40212

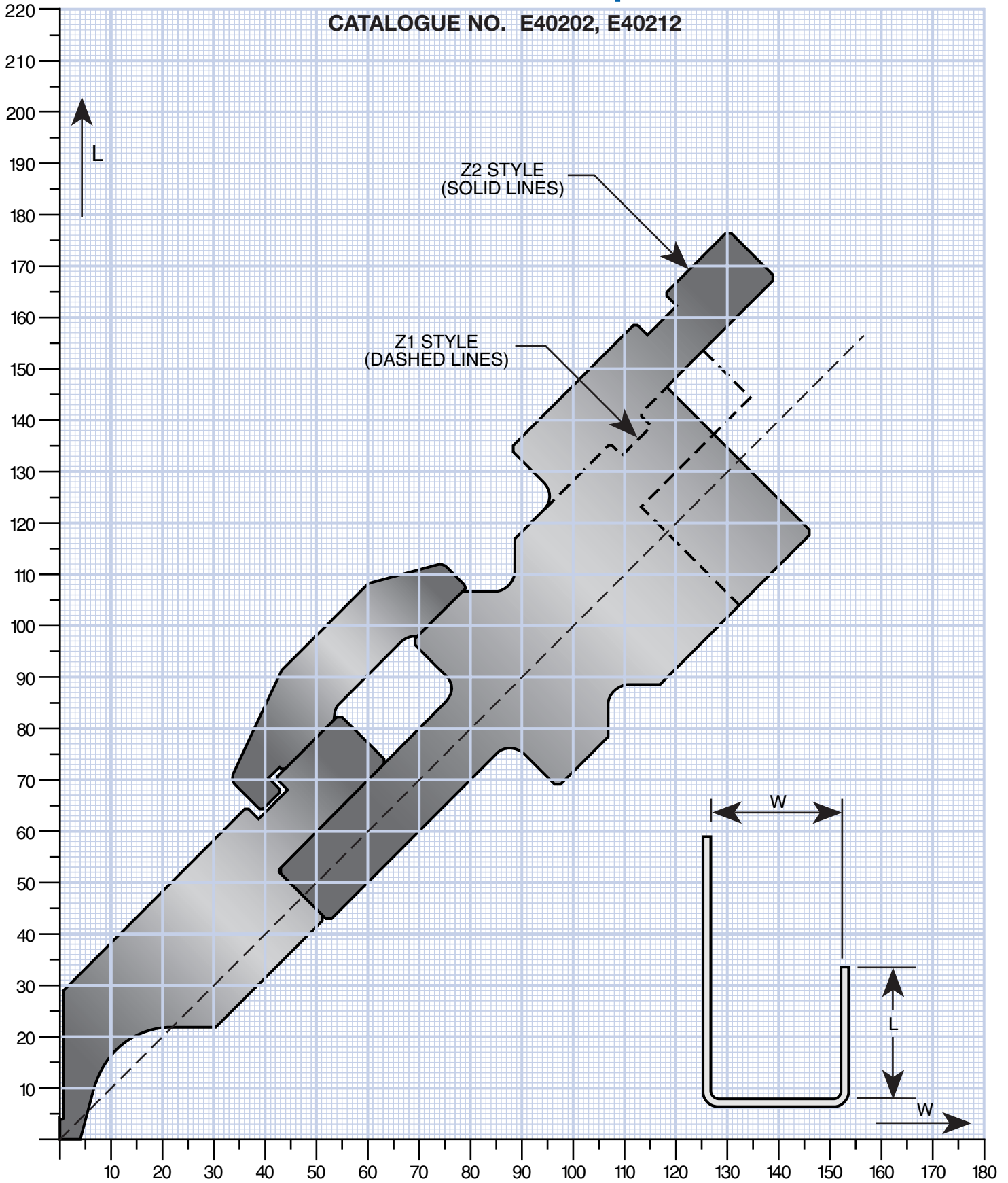

Tel: +44 (0) 1793 831818
 Email: sales@wilsontool.eu.com

Free Phone:
 Free Fax:

0800 373748
 0800 373758

Tel Free:
 Fax Free:

1-800 70 90 09 Ireland
 1-800 53 55 38 Ireland



Bend Limit Graph

CATALOGUE NO. E40302, E40308

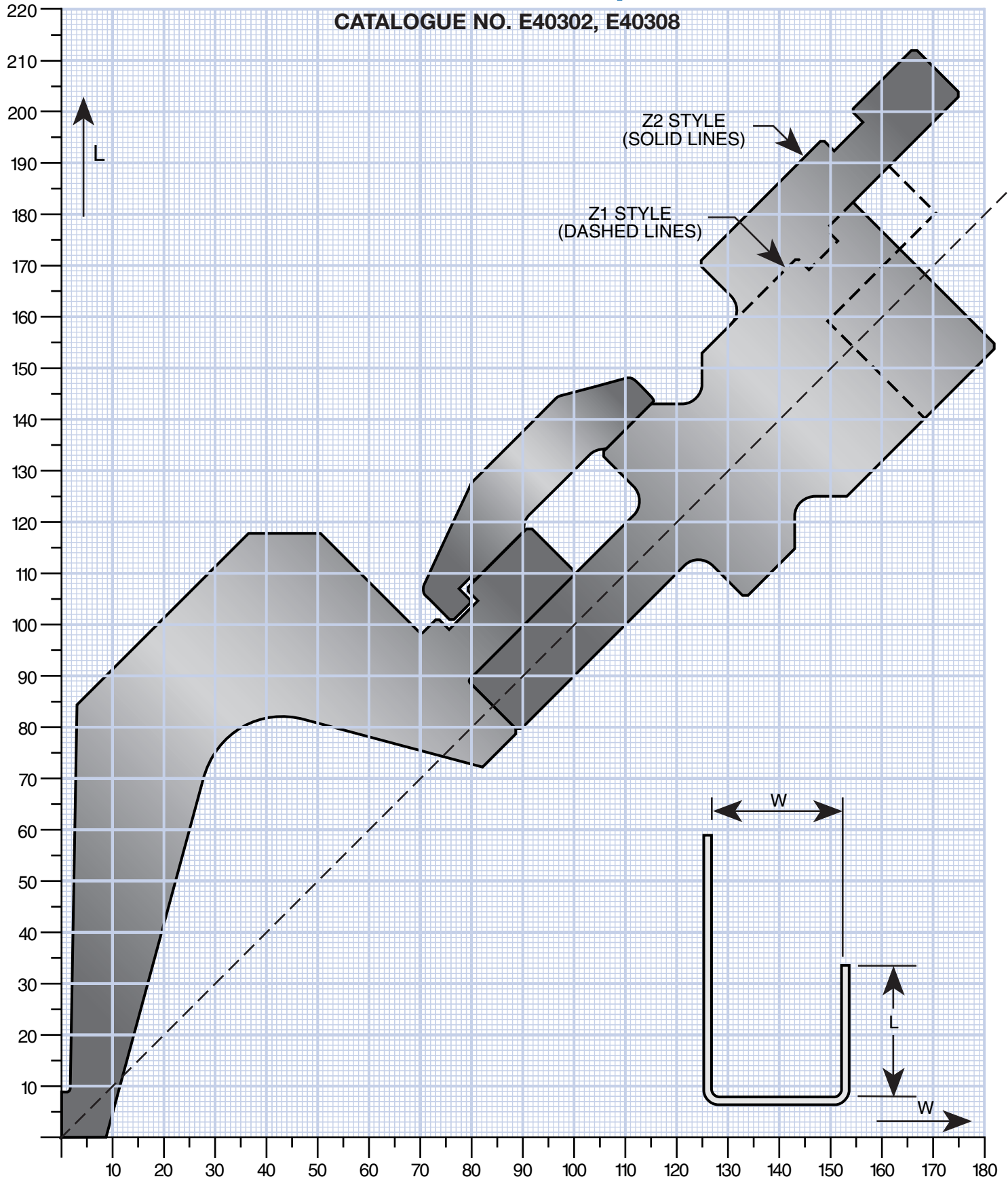

Bend Limit Graph

CATALOGUE NO. E40402, E40408, E40415, E40430, E40502

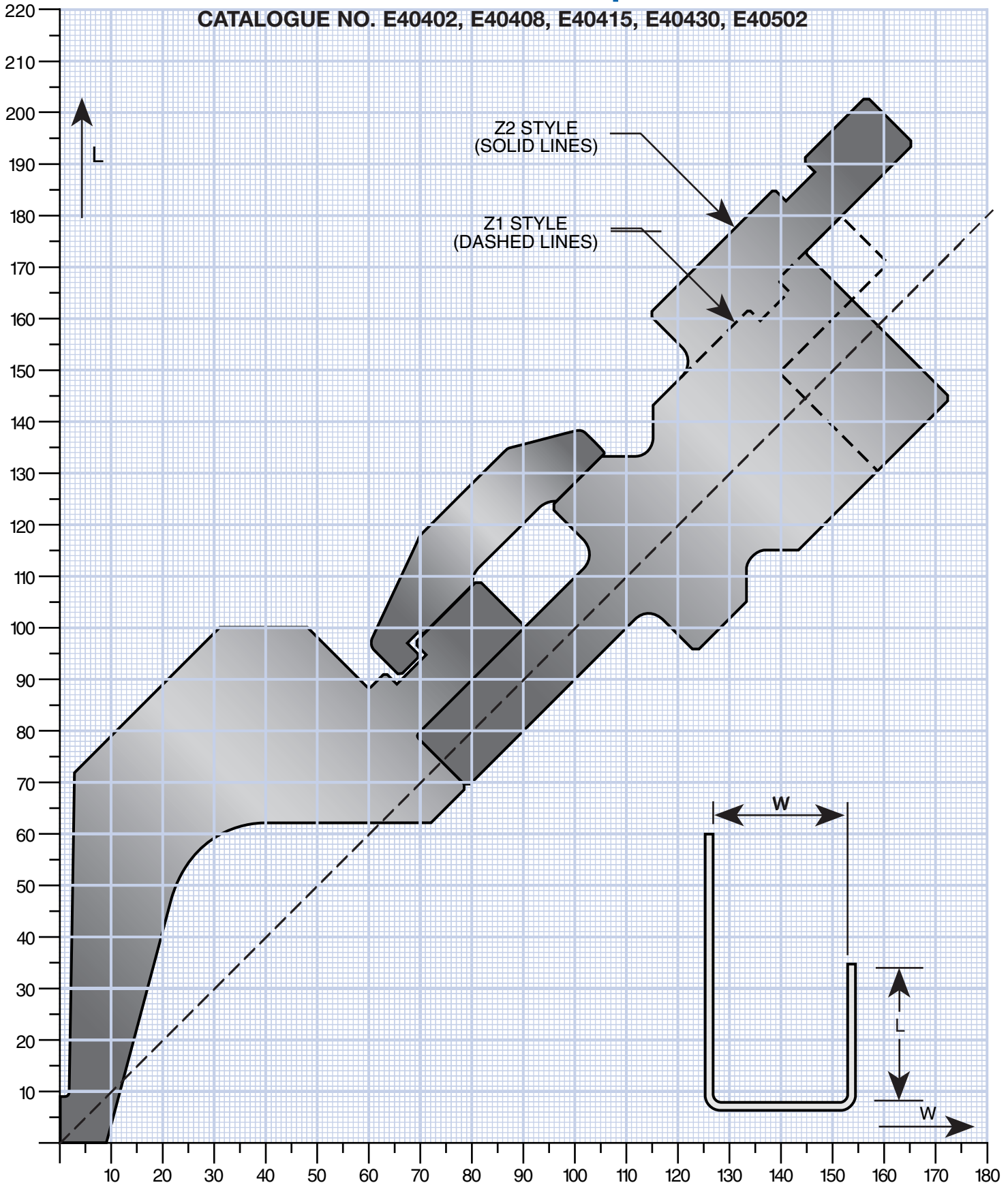

Tel: +44 (0) 1793 831818
Email: sales@wilsontool.eu.com

Free Phone:
Free Fax:

0800 373748
0800 373758

Tel Free:
Fax Free:

1-800 70 90 09 Ireland
1-800 53 55 38 Ireland



Bend Limit Graph

CATALOGUE NO. E40602, E40608, E40615, E40630

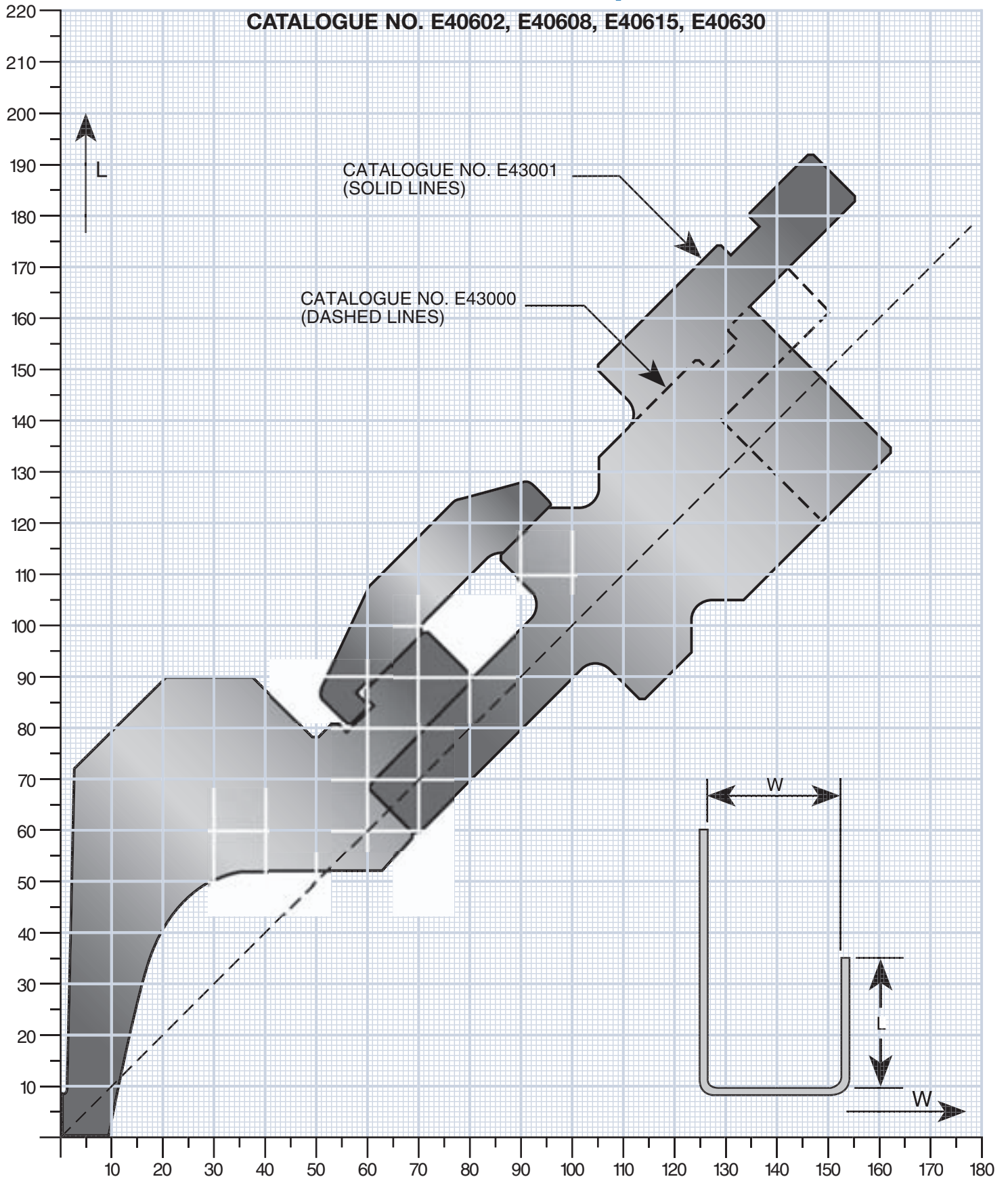

Bend Limit Graph

CATALOGUE NO. E40702, E40708, E40712, E40718

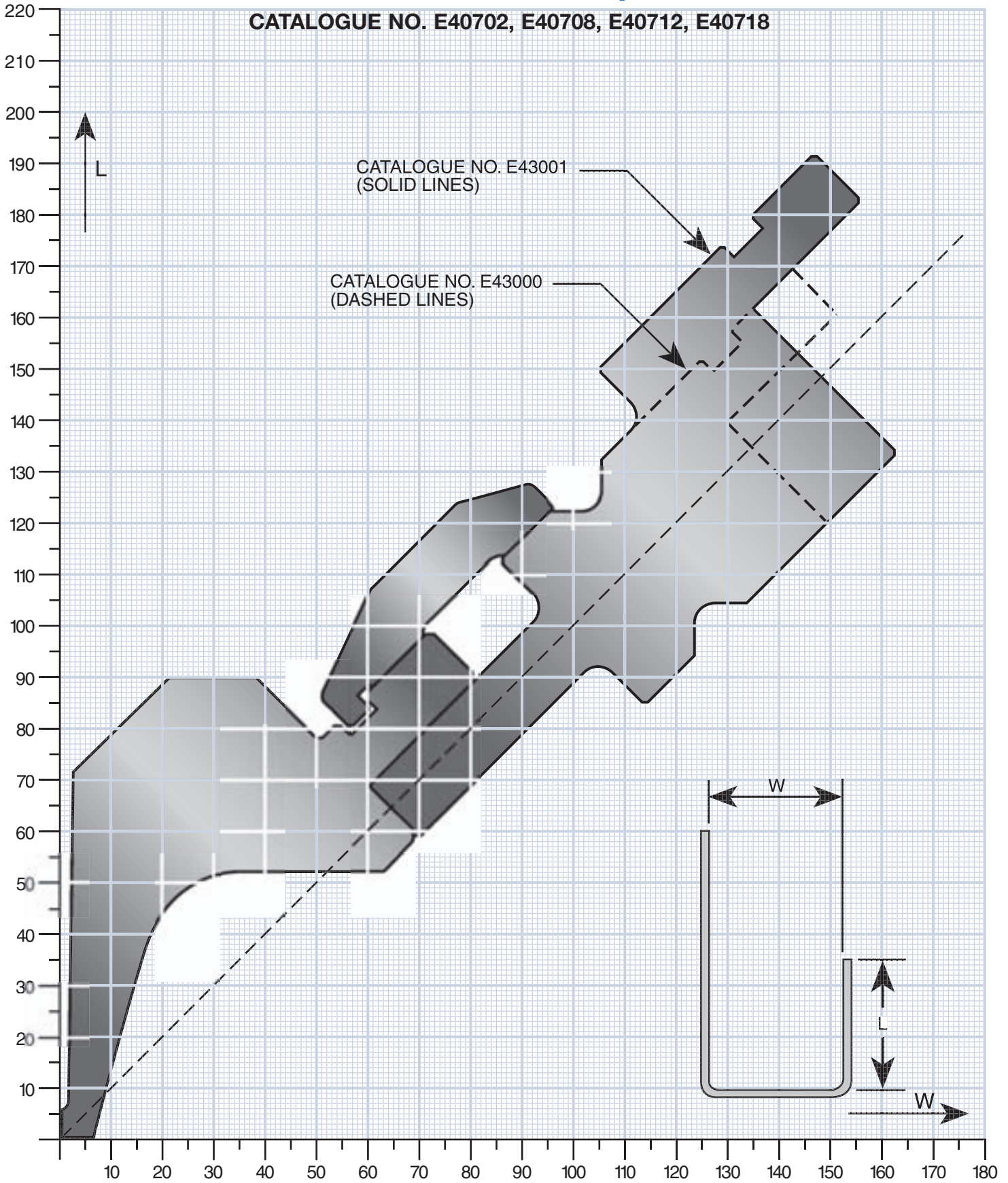

Tel: +44 (0) 1793 831818
 Email: sales@wilsontool.eu.com

Free Phone:
 Free Fax:

0800 373748
 0800 373758

Tel Free:
 Fax Free:

1-800 70 90 09 Ireland
 1-800 53 55 38 Ireland



Bend Limit Graph

CATALOGUE NO. E44540, E44560

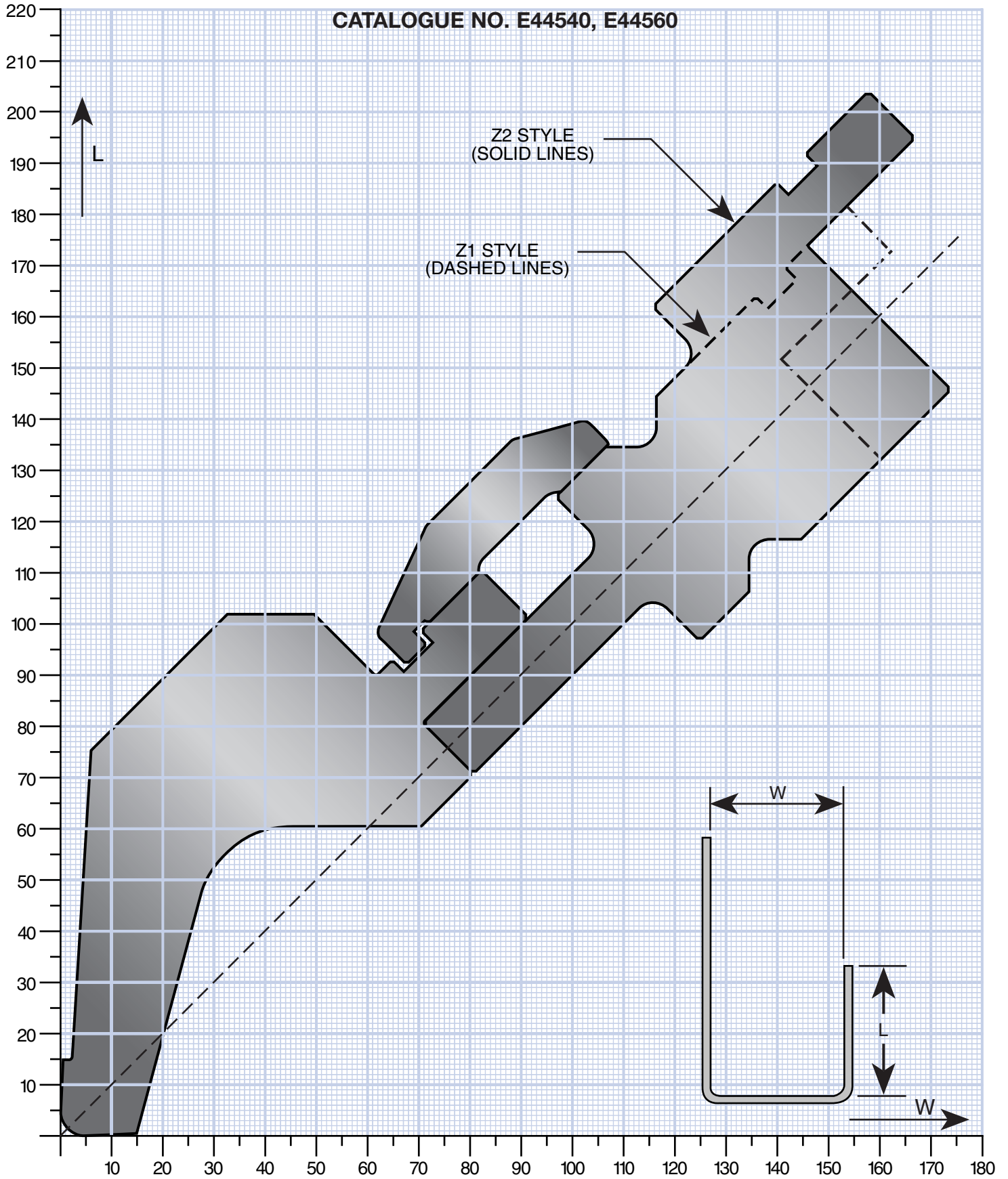

Bend Limit Graph

CATALOGUE NO. E40802, E40902

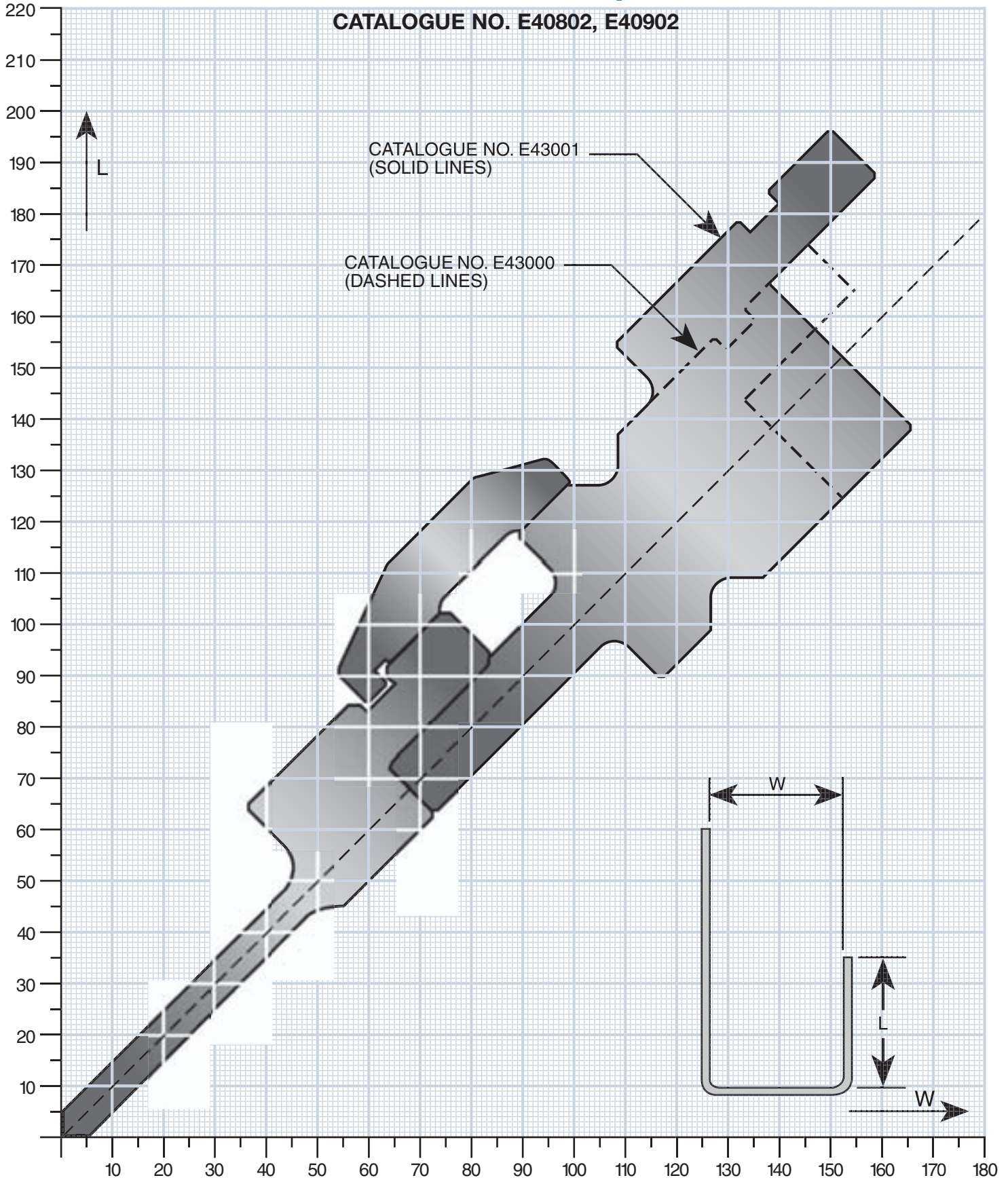

Tel: +44 (0) 1793 831818
Email: sales@wilsontool.eu.com

Free Phone:
Free Fax:

0800 373748
0800 373758

Tel Free:
Fax Free:

1-800 70 90 09 Ireland
1-800 53 55 38 Ireland

Bend Limit Graph

CATALOGUE NO. E41002

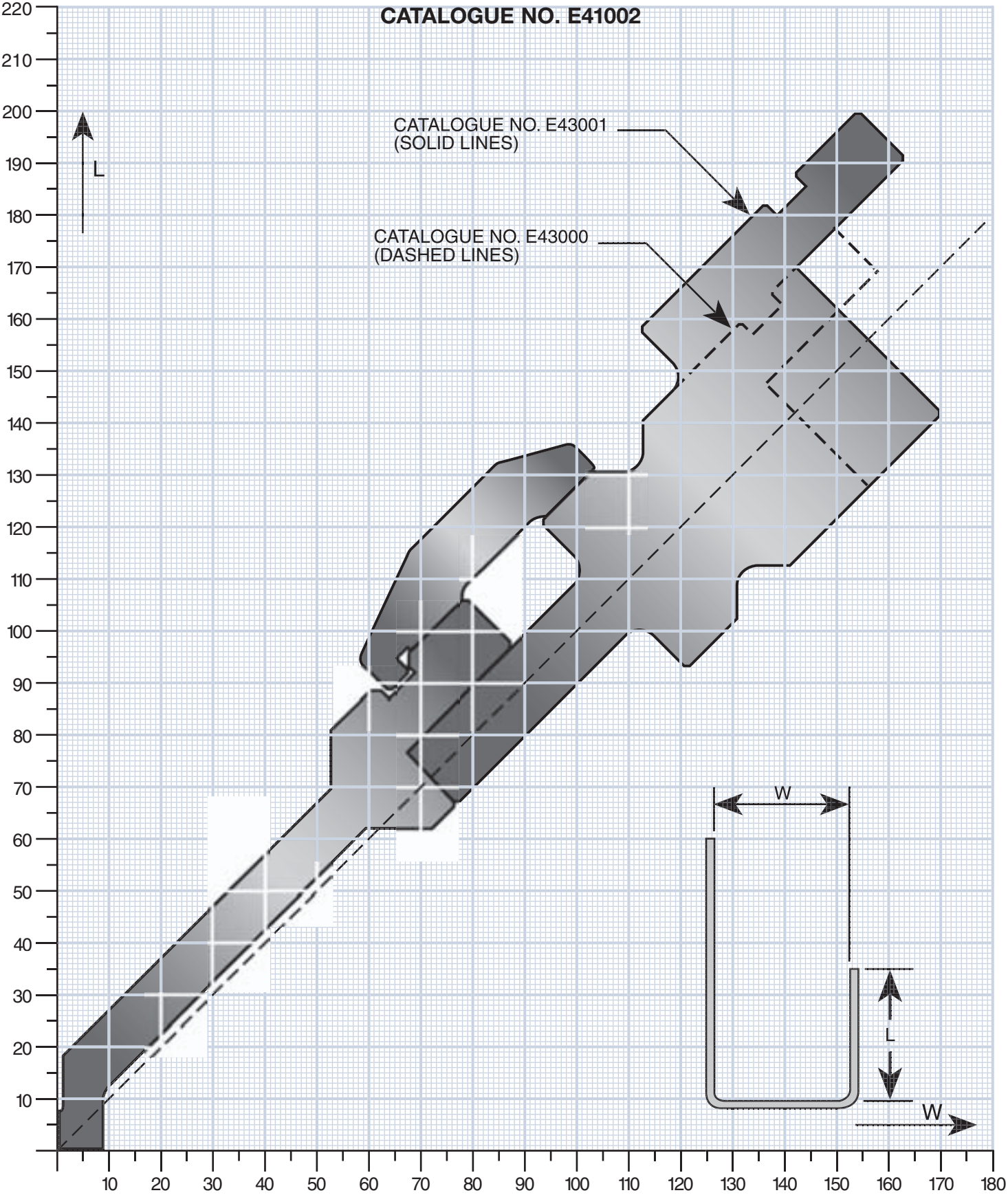

Bend Limit Graph

CATALOGUE NO. E41102, E41202

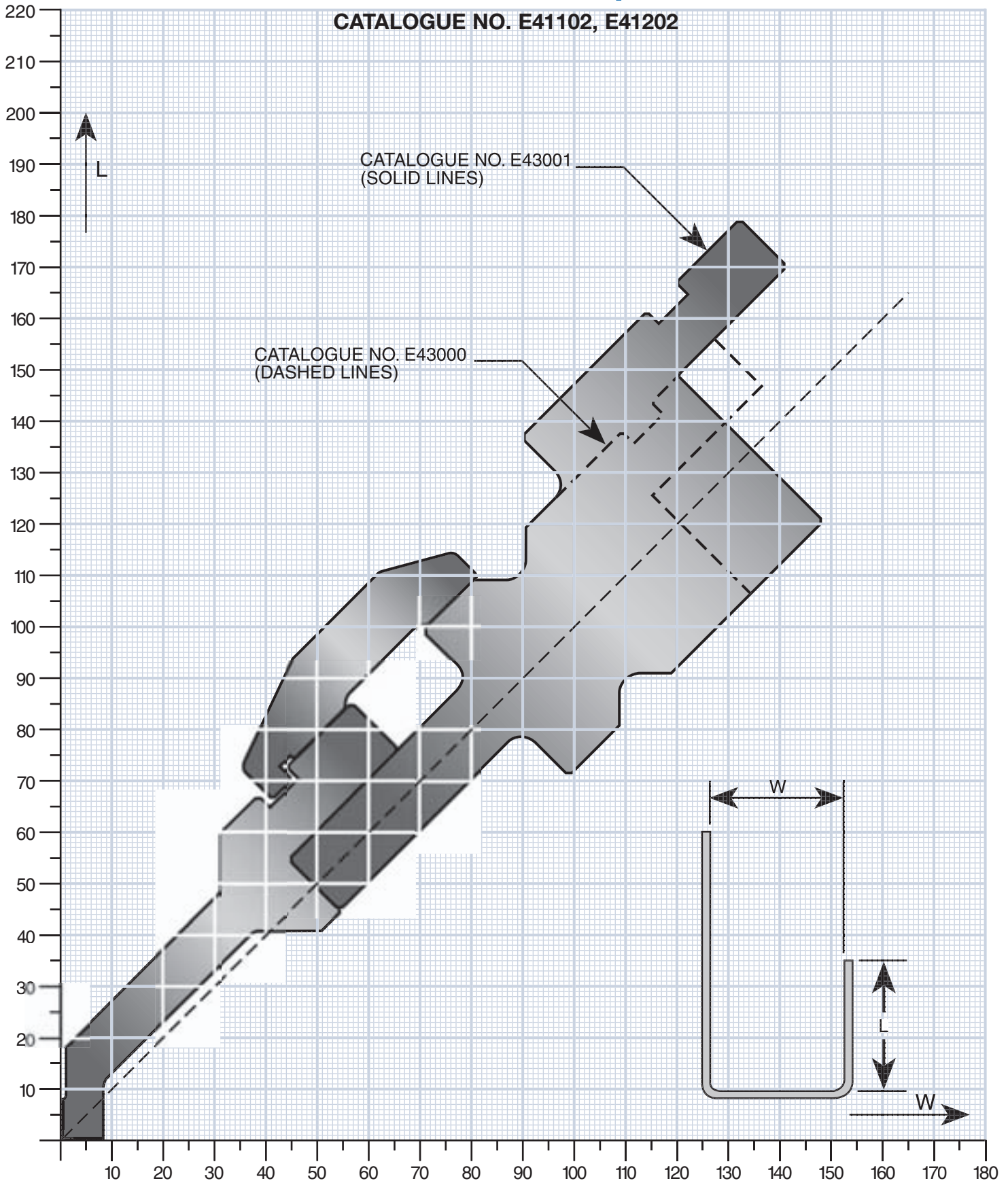

Tel: +44 (0) 1793 831818
 Email: sales@wilsontool.eu.com

Free Phone:
 Free Fax:

0800 373748
 0800 373758

Tel Free:
 Fax Free:

1-800 70 90 09 Ireland
 1-800 53 55 38 Ireland

Bend Limit Graph

CATALOGUE NO. E41908

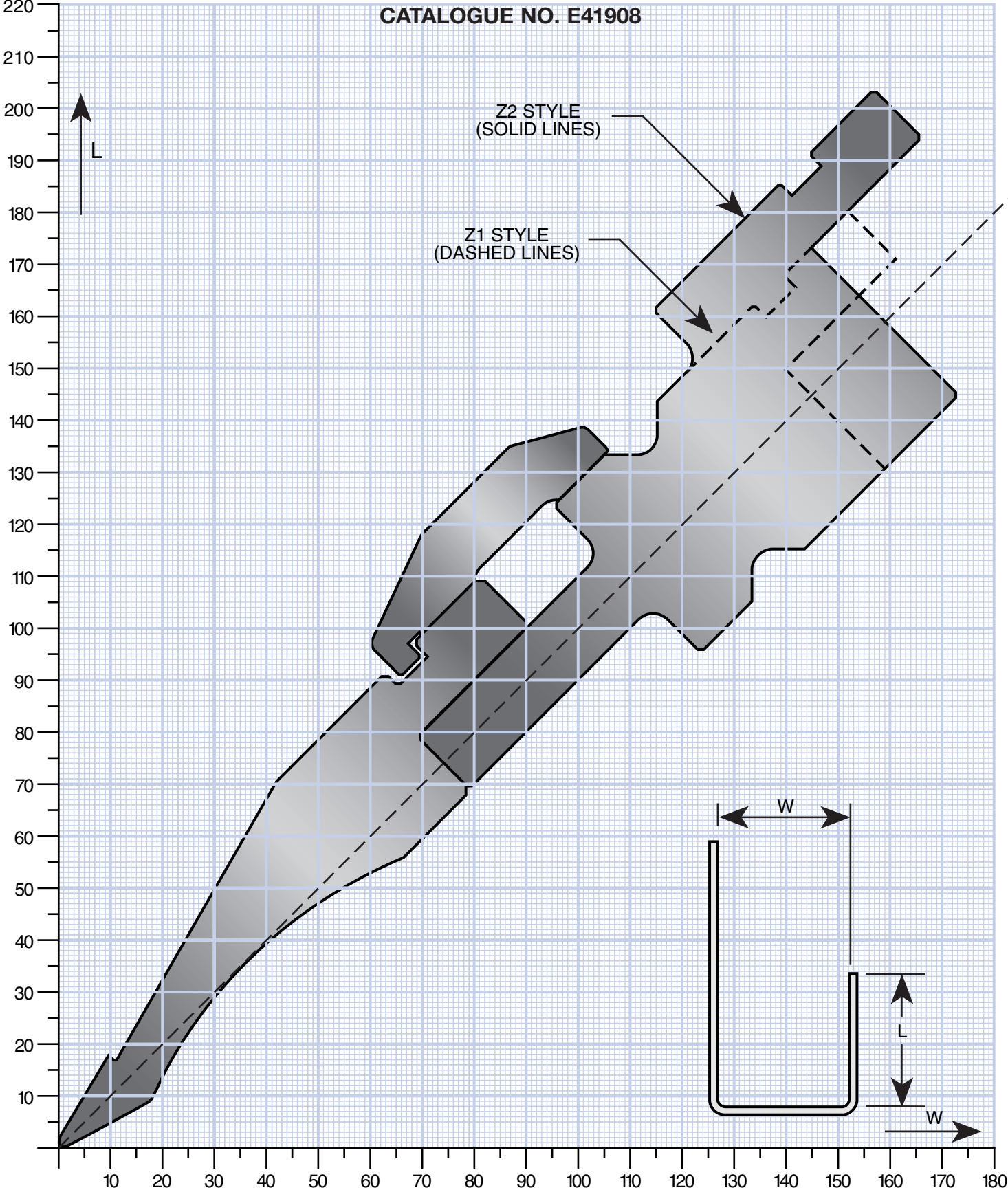

Bend Limit Graph

CATALOGUE NO. E42610

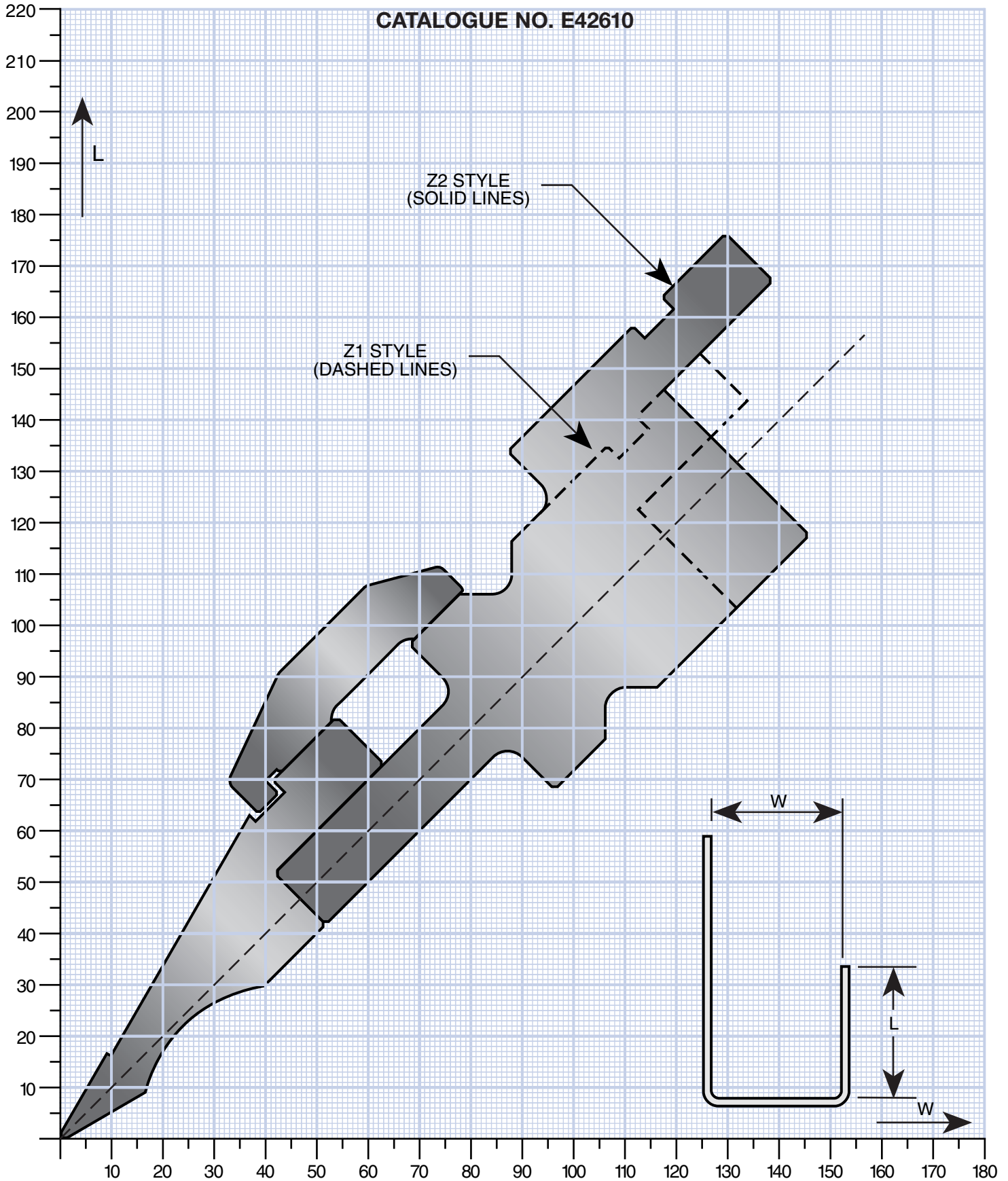

Tel: +44 (0) 1793 831818
Email: sales@wilsontool.eu.com

Free Phone:
Free Fax:

0800 373748
0800 373758

Tel Free:
Fax Free:

1-800 70 90 09 Ireland
1-800 53 55 38 Ireland

Bend Limit Graph

CATALOGUE NO. E44000

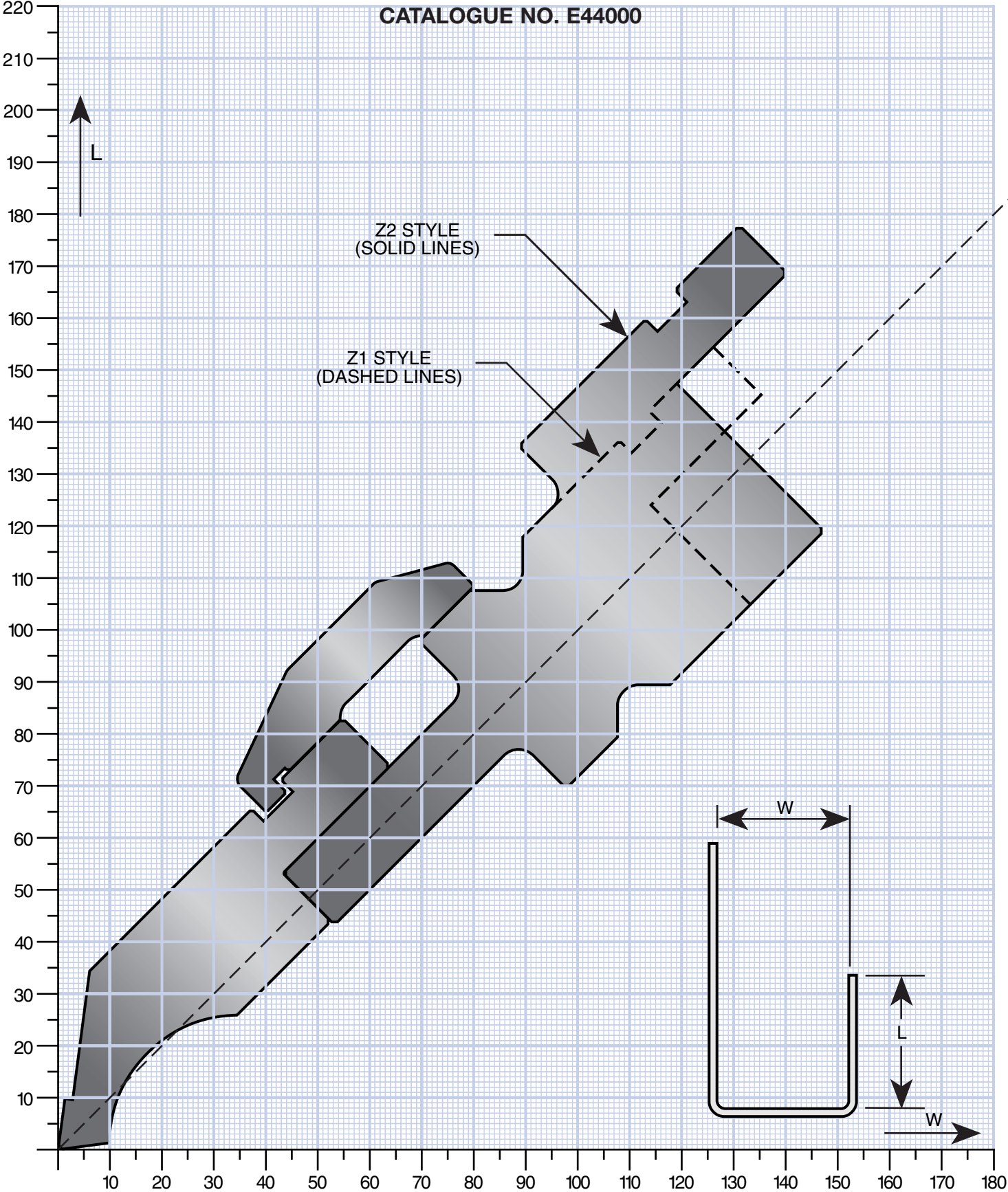

Bend Limit Graph

CATALOGUE NO. E44030

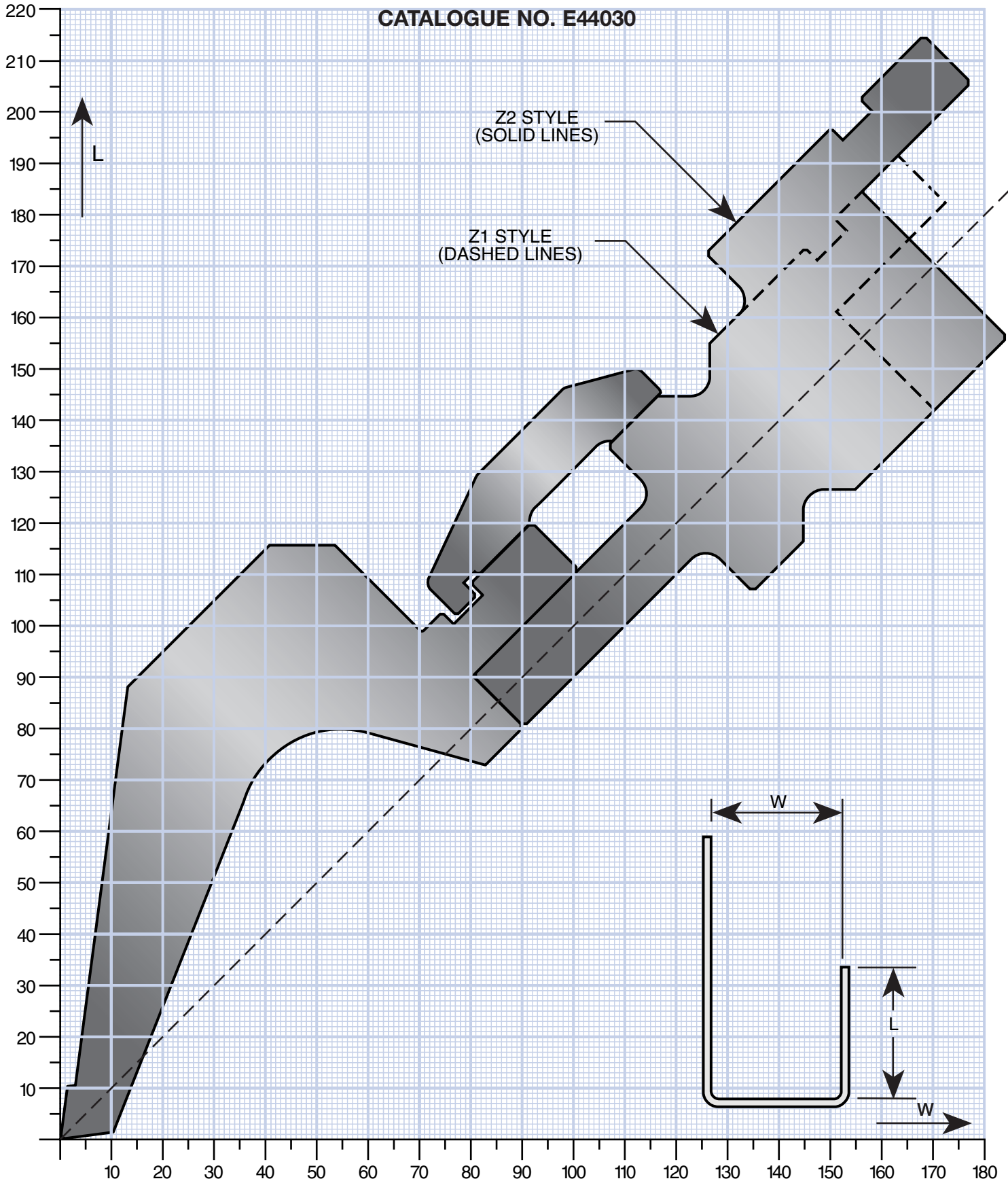

Tel: +44 (0) 1793 831818
 Email: sales@wilsontool.eu.com

Free Phone:
 Free Fax:

0800 373748
 0800 373758

Tel Free:
 Fax Free:

1-800 70 90 09 Ireland
 1-800 53 55 38 Ireland



Bend Limit Graph

CATALOGUE NO. E44020

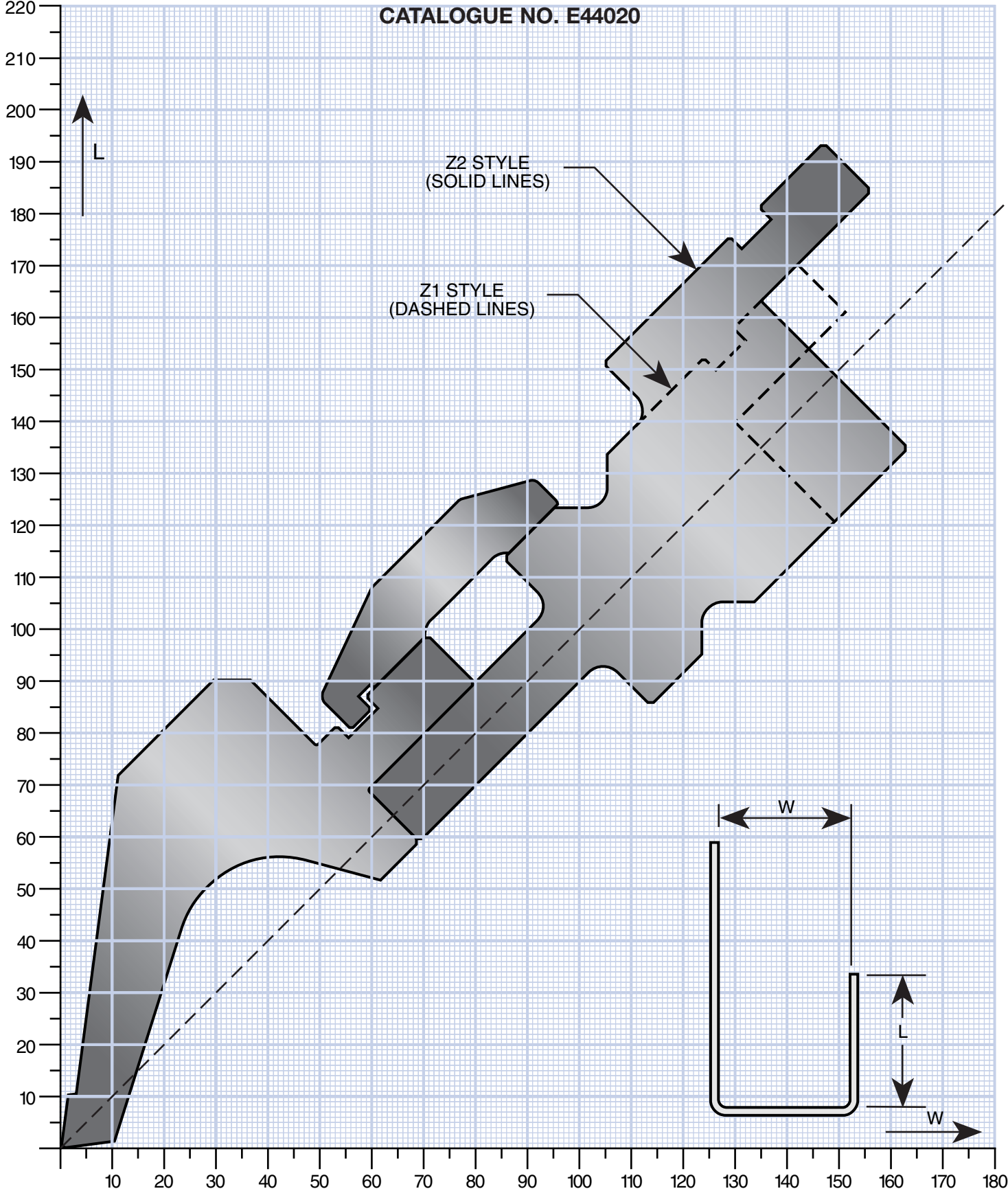

Bend Limit Graph

CATALOGUE NO. E44010

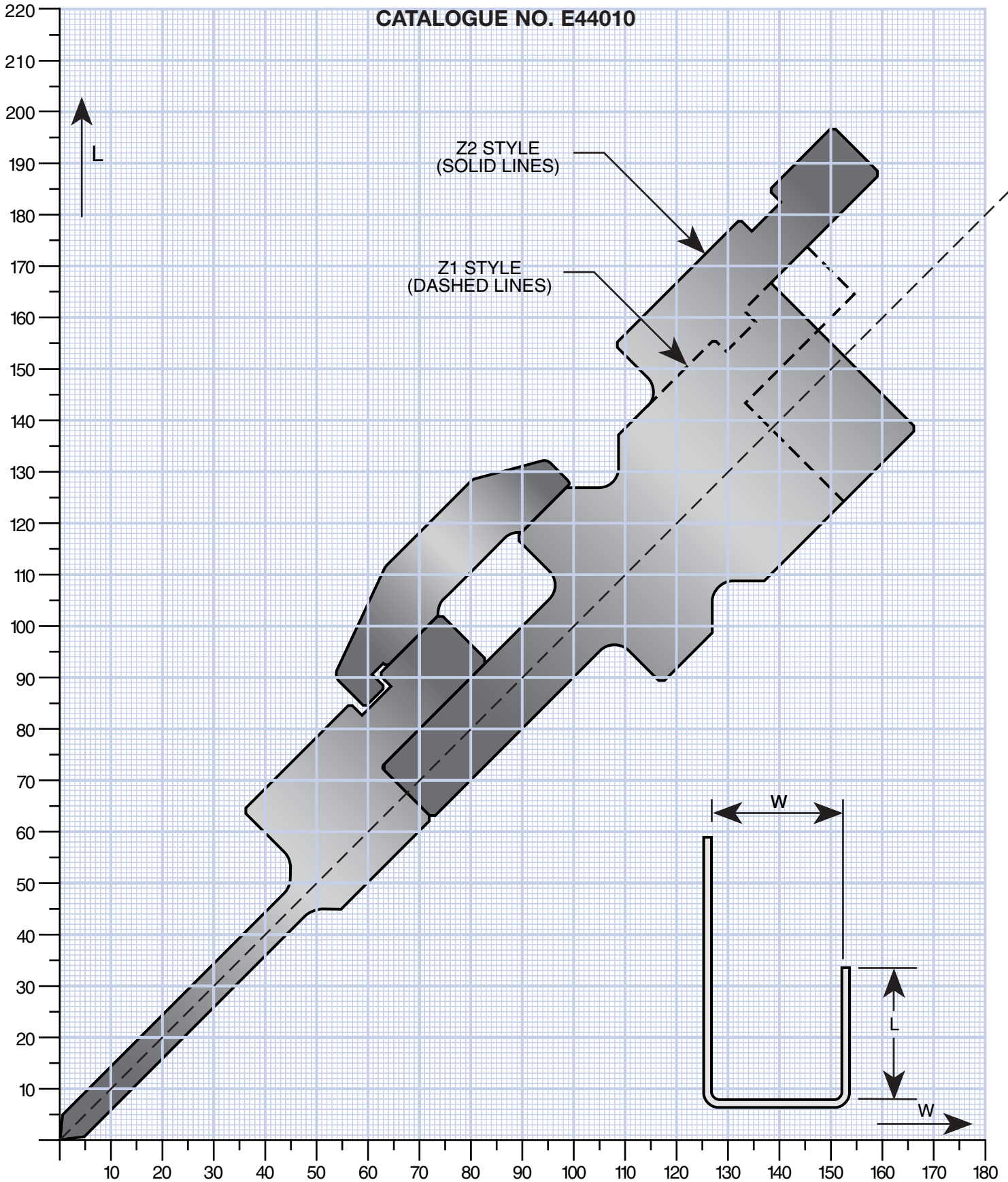

Tel: +44 (0) 1793 831818
Email: sales@wilsontool.eu.com

Free Phone:
Free Fax:

0800 373748
0800 373758

Tel Free:
Fax Free:

1-800 70 90 09 Ireland
1-800 53 55 38 Ireland

Bend Limit Graph

CATALOGUE NO. E44040

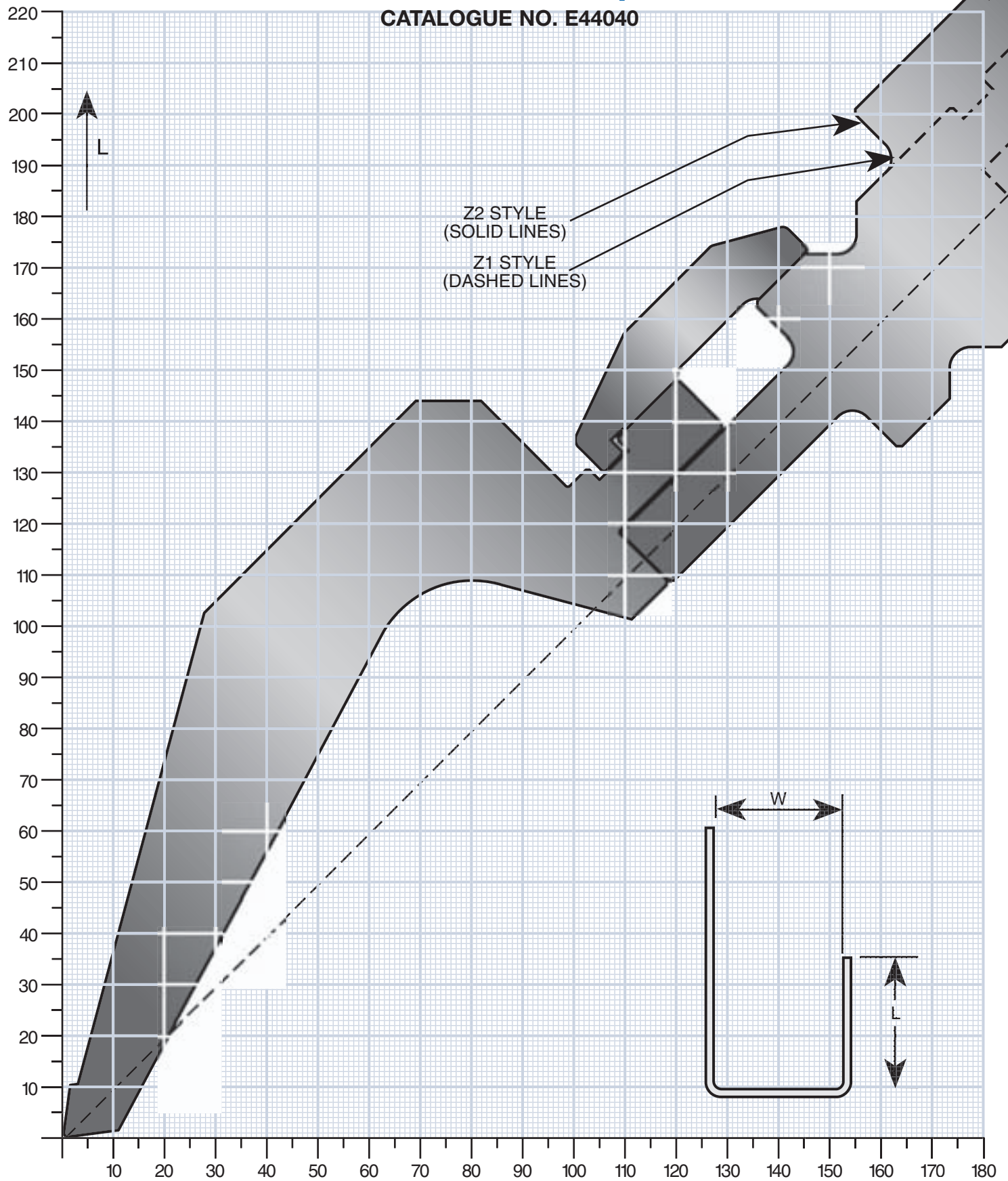

Bend Limit Graph

CATALOGUE NO. E43002

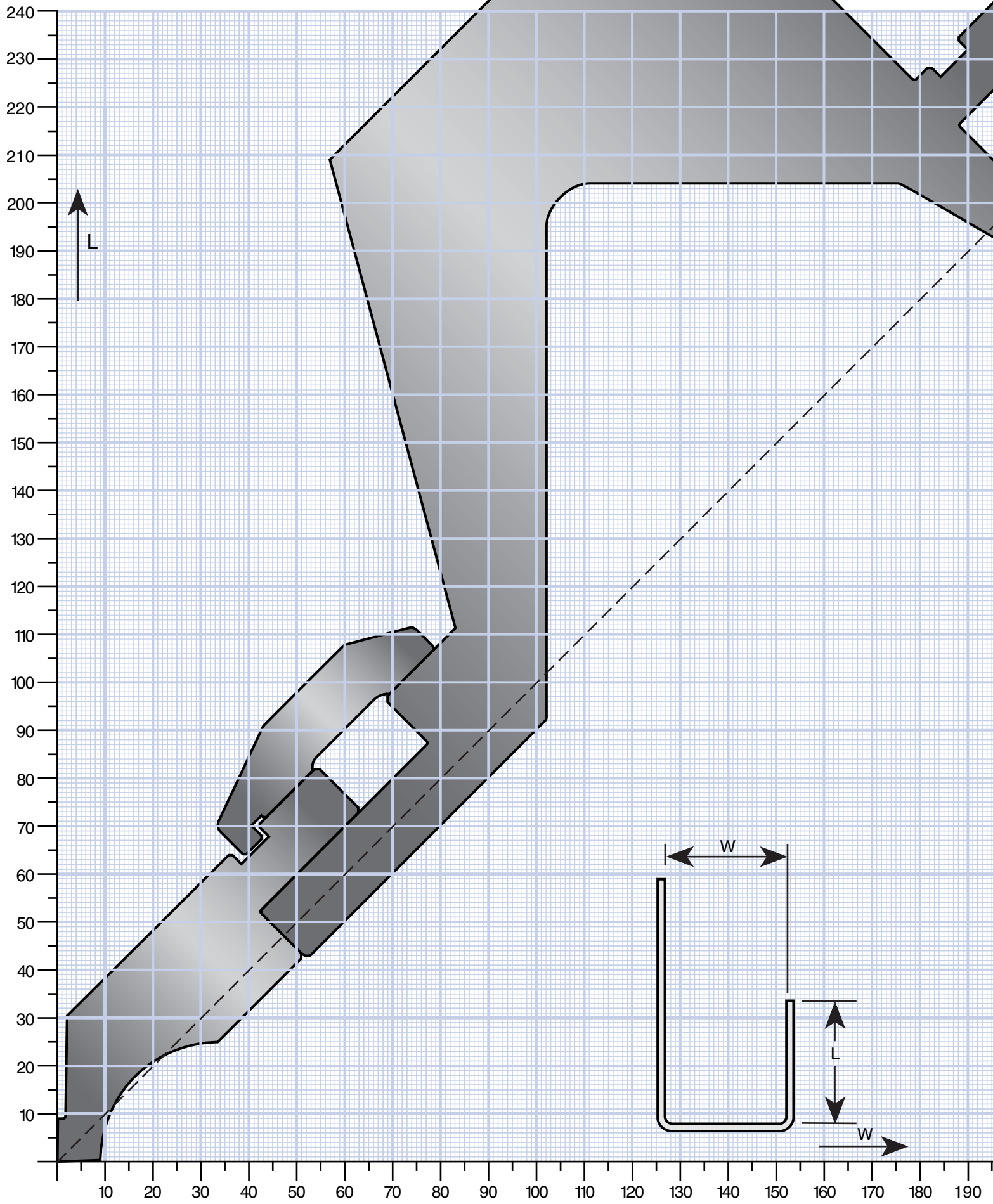

Quick Change 2V Dies

Cat. No. E42000 - E42007

Part No. E42000

90°

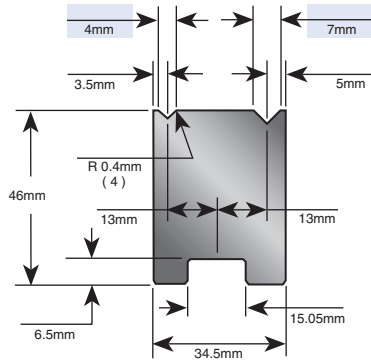

Part No. E42001

90°

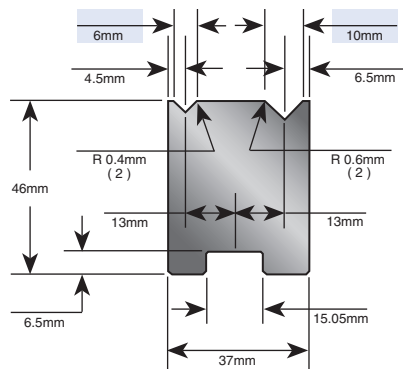

Part No. E42002

90°

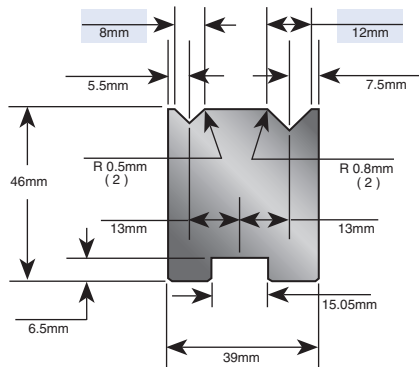

Part No. E42003

90°

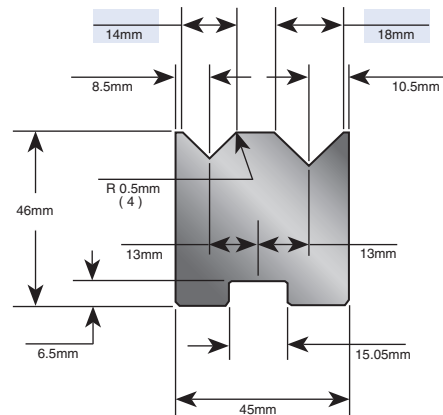

*Note: V-opening modifications and die relief available at additional cost. Contact the sales desk for prices and lead times.

Nitrex™ (HRC-60) is standard on the dies on this page at no additional cost.

Quick Change 2V Dies

Cat. No. E42000 - E42007

Part No. E42004

88°

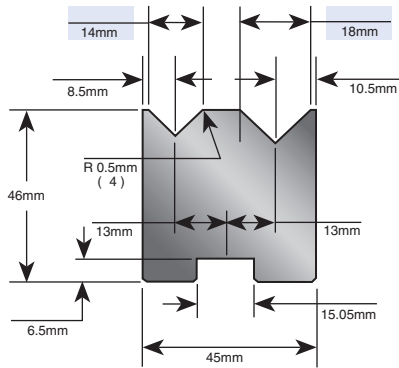

Part No. E42005

88°

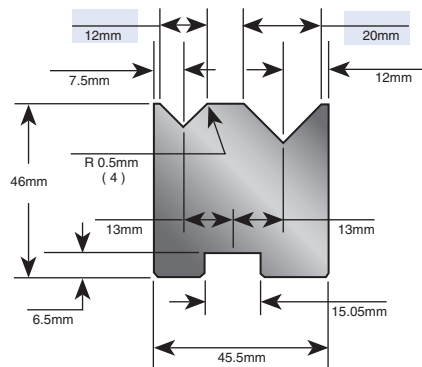

Part No. E42006

88°

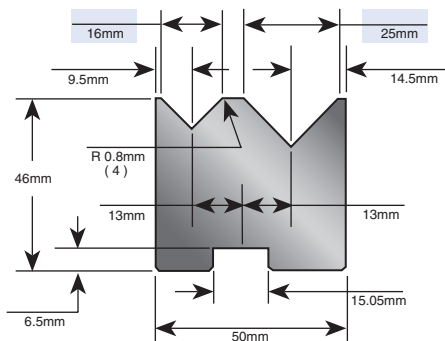

Part No. E42007

88°

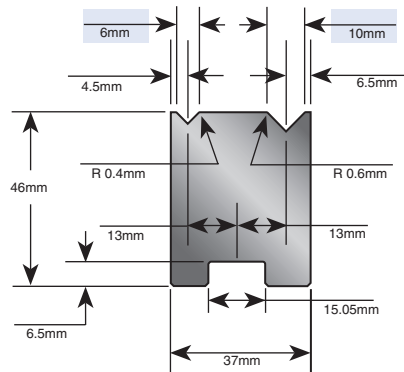

CATALOGUE NUMBER	MAX. TON per metre	L 835mm	S 415mm	X SECTIONALIZED
E42000	60			
*E42001	70			
*E42002	80			
E42003	100			
*E42004	100			
*E42005	100			
*E42006	70			
E42007	70			

*Note: V-opening modifications and die relief available at additional cost. Contact the sales desk for prices and lead times.

Nitrex™ (HRC-60) is standard on the dies on this page at no additional cost.

*Quick change 2V dies available in urethane. Please call our application sales desk for pricing and lead time.

Tel: +44 (0) 1793 831818
Email: sales@wilsontool.eu.com

Free Phone: 0800 373748
Free Fax: 0800 373758

Tel Free: 1-800 70 90 09 Ireland
Fax Free: 1-800 53 55 38 Ireland

Quick Change 2V Dies With Large Shoulder Radii

Cat. No. E42010 - E42012

Part No. E42010

90°

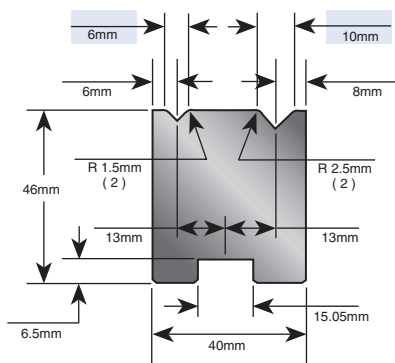

Part No. E42012

88°

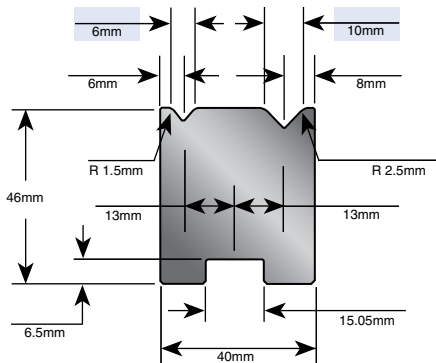

Part No. E42011

88°

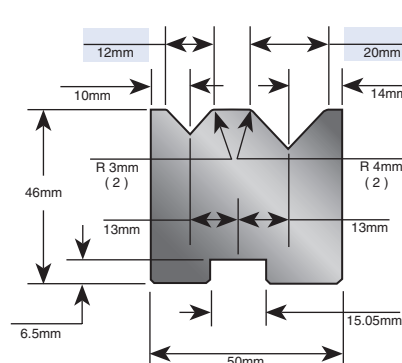

CATALOGUE NUMBER	MAX. TON per metre	L 835mm	S 415mm	X SECTIONALIZED
E42010	80			
E42012	80			
E42011	100			

*Note: V-opening modifications and die relief available at additional cost. Contact the sales desk for prices and lead times.

Nitrex™(HRC-60) is standard on the dies on this page at no additional cost.

Acute-Angle Quick Change 2V Dies

Cat. No. E42020 and E42021

Part No. E42020

30°

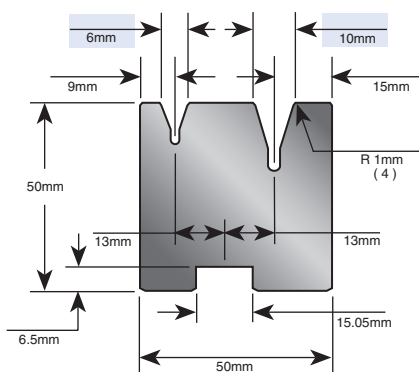

Part No. E42021

30°

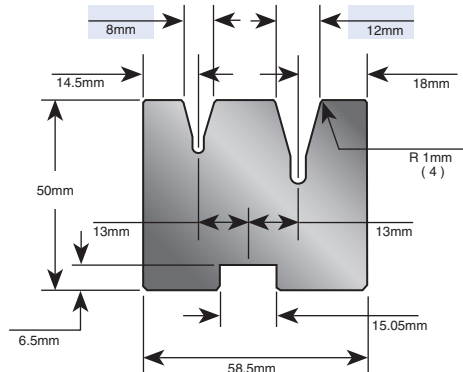

CATALOGUE NUMBER	MAX. TON per metre	L 835mm	S 415mm	X SECTIONALIZED
E42020	30			
*E42021	30			

*Note: V-opening modifications and die relief available at additional cost. Contact the sales desk for prices and lead times.

Nitrex™(HRC-60) is standard on the dies on this page at no additional cost.

*Quick change 2V dies available in urethane. Please call our application sales desk for pricing and lead time.

Quick Change 75° 2V Dies

Cat. No. E44100 - E44103

Part No. E44100

75°

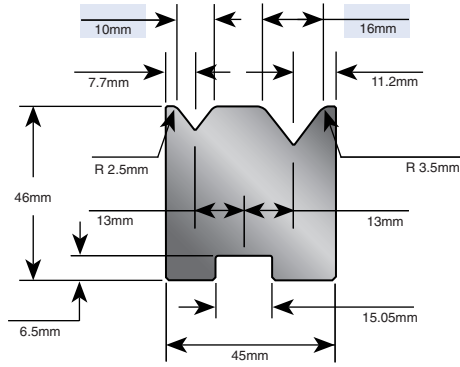

Part No. E44101

75°

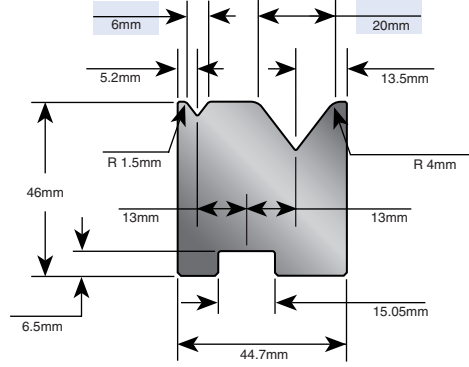

Part No. E44102

75°

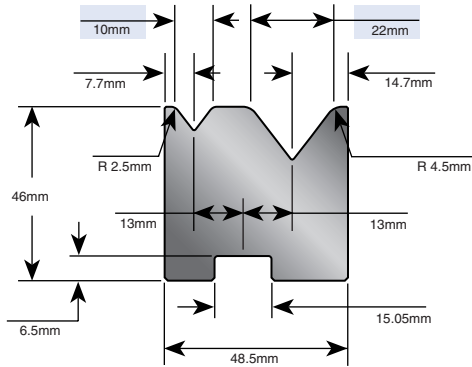

Part No. E44103

75°

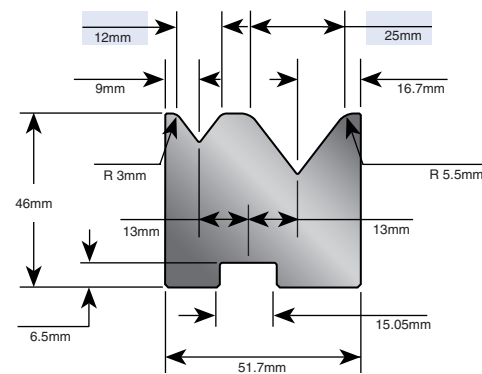

CATALOGUE NUMBER	MAX. TON per metre	L 835mm	S 415mm	X SECTIONALIZED
E44100	100			
E44101	100			
E44102	100			
E44103	100			

*Note: V-opening modifications and die relief available at additional cost. Contact the sales desk for prices and lead times.

Nitrex™(HRC-60) is standard on the dies on this page at no additional cost.

Tel: +44 (0) 1793 831818
Email: sales@wilsontool.eu.com

Free Phone:
Free Fax:

0800 373748
0800 373758

Tel Free:
Fax Free:

1-800 70 90 09 Ireland
1-800 53 55 38 Ireland



2V Dies (Old Style)

Cat. No. E42030 - E42036

Part No. E42030
90°

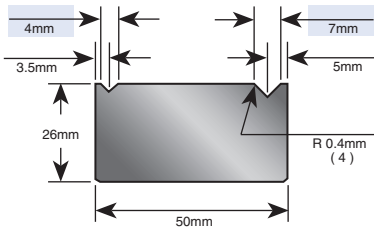

Part No. E42031
90°

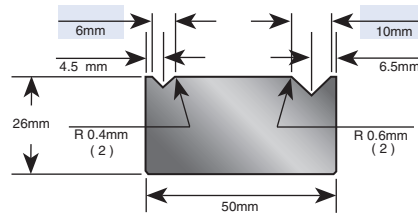

Part No. E42032
90°

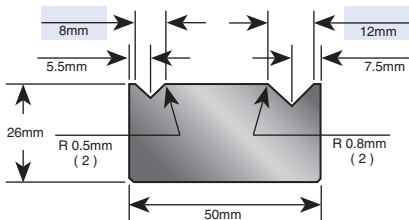

Part No. E42033
90°

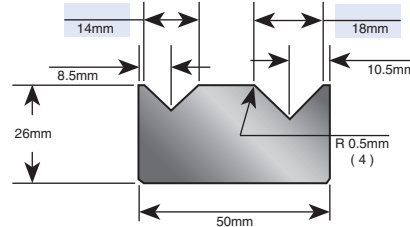

Part No. E42034
88°

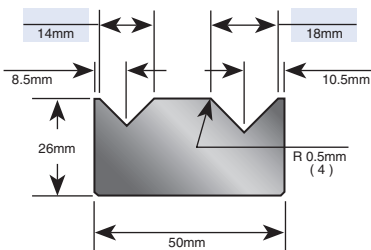

Part No. E42035
88°

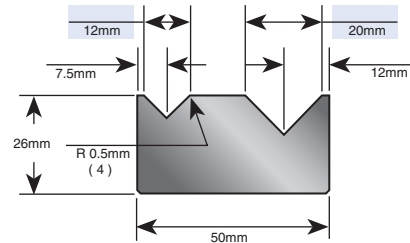

Part No. E42036
88°

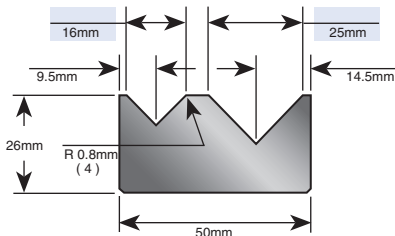

CATALOGUE NUMBER	MAX. TON per metre	L 835mm	S 415mm
E42030	60		
E42031	70		
E42032	80		
E42033	100		
E42034	100		
E42035	100		
E42036	70		

*Note: All mounting hardware is included.

V-opening modifications and die relief available at additional cost. Contact the sales desk for prices and lead times.

Nitrex™(HRC-60) is standard on the dies on this page at no additional cost.

2V Dies With Large Shoulder Radii (Old Style)

Cat. No. E42040 and E42041

Part No. E42040
90°

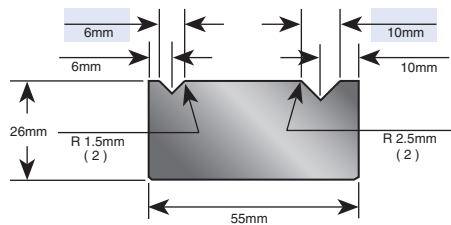

Part No. E42041
88°

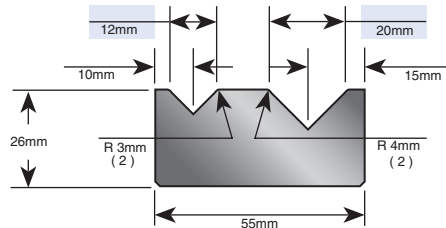

CATALOGUE NUMBER	MAX. TON per metre	L 835mm	S 415mm
E42040	80		
E42041	100		

*Note: All mounting hardware is included.

V-opening modifications and die relief available at additional cost. Contact the sales desk for prices and lead times.

Nitrex™(HRC-60) is standard on the dies on this page at no additional cost.

Sectionalized 2V Dies (Old Style)

Cat. No. E42050 - E42051

Part No. E42050
90°

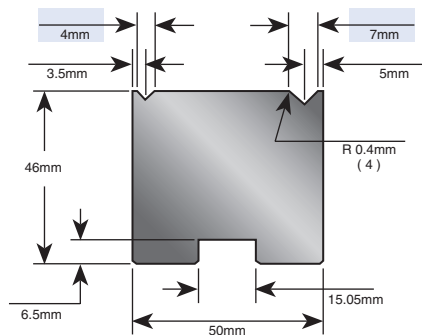

Part No. E42051
90°

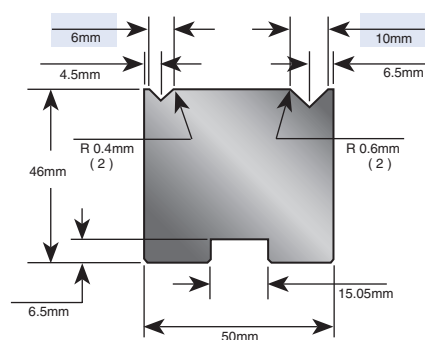

CATALOGUE NUMBER	MAX. TON per metre	X SECTIONALIZED
E42050	60	
E42051	70	

*Note: V-opening modifications and die relief available at additional cost. Contact the sales desk for prices and lead times.

Nitrex™(HRC-60) is standard on the dies on this page at no additional cost.

Tel: +44 (0) 1793 831818
Email: sales@wilsontool.eu.com

Free Phone:
Free Fax:

0800 373748
0800 373758

Tel Free:
Fax Free:

1-800 70 90 09 Ireland
1-800 53 55 38 Ireland

Sectionalized 2V Dies (Old Style)

Cat. No. E42052 - E42056

Part No. E42052
90°

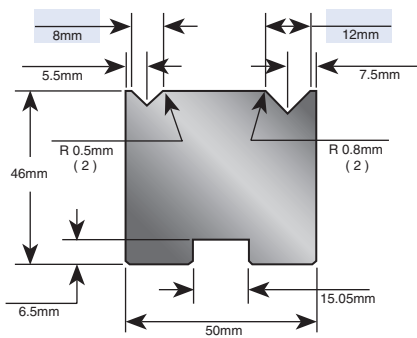

Part No. E42053
90°

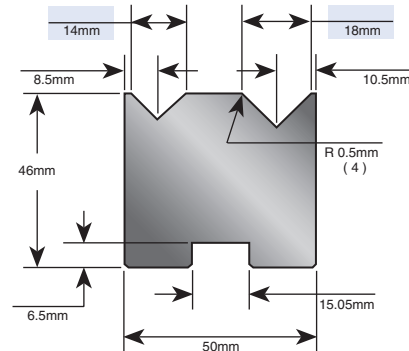

Part No. E42054
88°

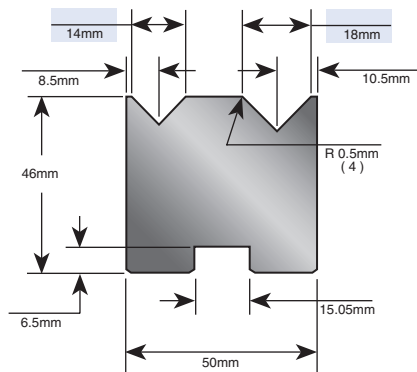

Part No. E42055
88°

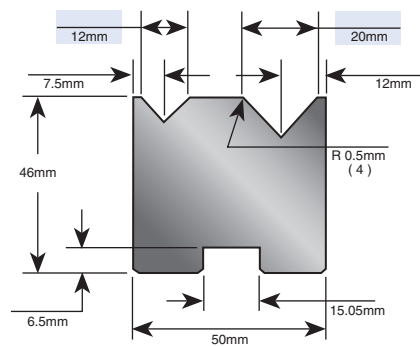

Part No. E42056
88°

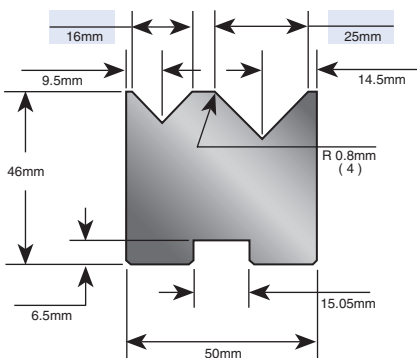

CATALOGUE NUMBER	MAX. TON per metre	X SECTIONALIZED
E42052	70	
E42053	100	
E42054	100	
E42055	100	
E42056	100	

*Note: V-opening modifications and die relief available at additional cost.
Contact the sales desk for prices and lead times.

Nitrex™ (HRC-60) is standard on the dies on this page at no additional cost.

Sectionalized 2V Dies With Large Shoulder Radii (Old Style)

Cat. No. E42070 - E42071

Part No. E42070
90°

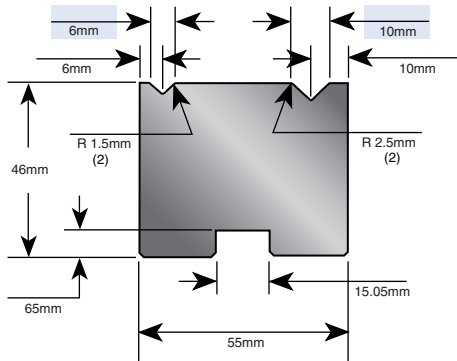

Part No. E42071
88°

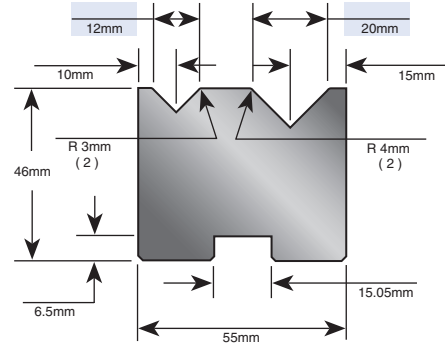

CATALOGUE NUMBER	MAX. TON per metre	X SECTIONALIZED
E42070	80	
E42071	100	

*Note: V-opening modifications and die relief available at additional cost.
Contact the sales desk for prices and lead times.

Nitrex™(HRC-60) is standard on the dies on this page at no additional cost.

Low Profile Sectionalized 2V Dies (Old Style)

Cat. No. E42061 - E42062

Part No. E42061
90°

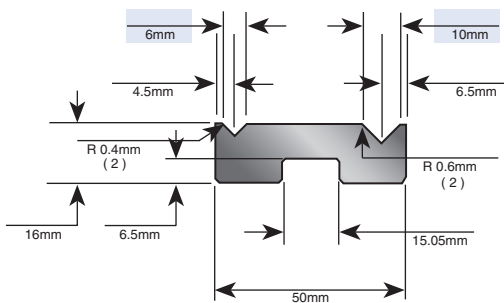

Part No. E42062
90°

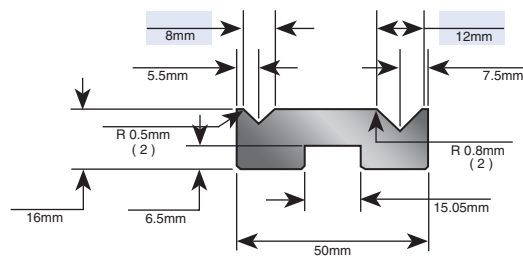

CATALOGUE NUMBER	MAX. TON per metre	X SECTIONALIZED
E42061	70	
E42062	70	

*Note: V-opening modifications and die relief available at additional cost.
Contact the sales desk for prices and lead times.

Nitrex™(HRC-60) is standard on the dies on this page at no additional cost.

Tel: +44 (0) 1793 831818
Email: sales@wilsontool.eu.com

Free Phone:
Free Fax:

0800 373748
0800 373758

Tel Free:
Fax Free:

1-800 70 90 09 Ireland
1-800 53 55 38 Ireland

2V Die Rail And Clamp

Cat. No. 42090 and 43553

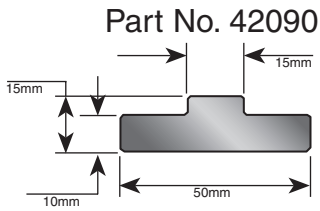

Part No. 43553

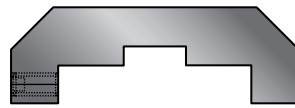

END VIEW



FRONT VIEW

CATALOGUE NUMBER	L 835mm	S 415mm
43553		
42090		

*Note: All mounting hardware is included.

Stacking Rails

Part No. 42091

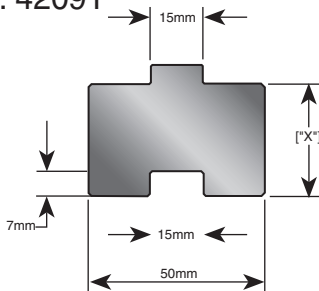

Cat. No. 42091 and 42092

Part No. 42092

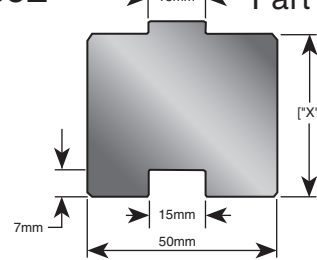

CATALOGUE NUMBER	HEIGHT RANGE	L 835mm	S 415mm	X SECTIONALIZED
42091	X= 14.6 - 31.75			
42092	X=31.76 - 69.85			

2V Die Holders

Cat. No. 43021 and 43022

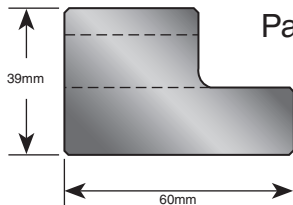

Part No. 43021

Part No. 43022

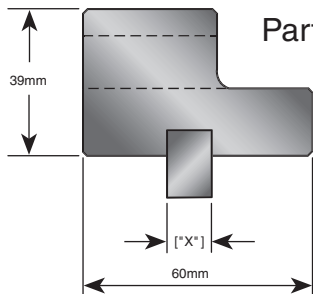
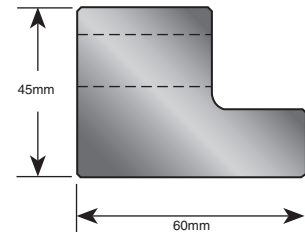

Part No. 43021 LAT
43021 SAT

Part No. 43022 LAT
43022 SAT

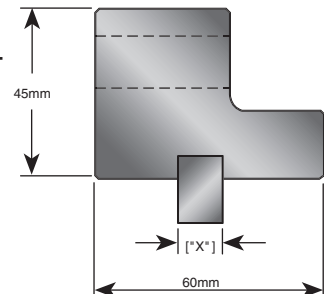

CATALOGUE NUMBER	L 835mm	S 415mm
43021		
43022		
43021 LAT		N/A
43021 SAT	N/A	
43022 LAT		N/A
43022 SAT	N/A	

Quick Change 1V Dies

Cat. No. E42100 - E42122

Part No. E42100
& E42120

90° & 88°

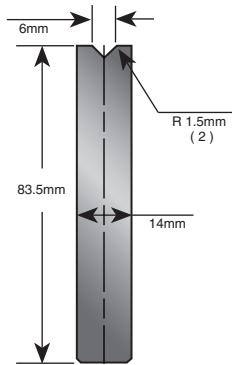

Part No. E42101
& E42121

90° & 88°

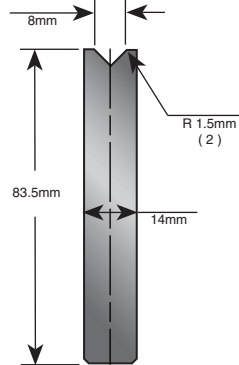

Part No. E42102
& E42122

90° & 88°

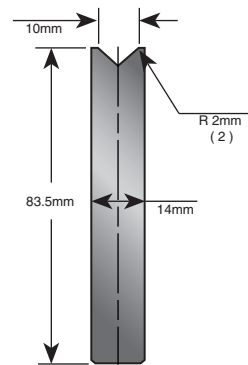

Part No. E42103

90°

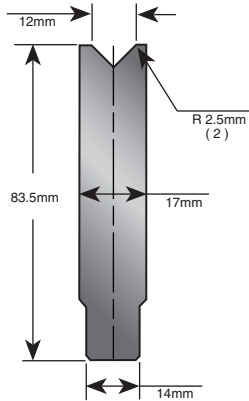

Part No. E42104

88°

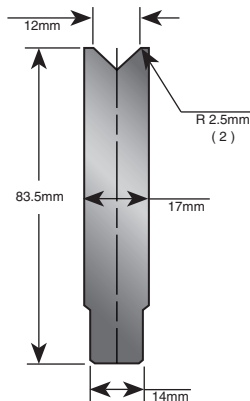

Part No. E42105

88°

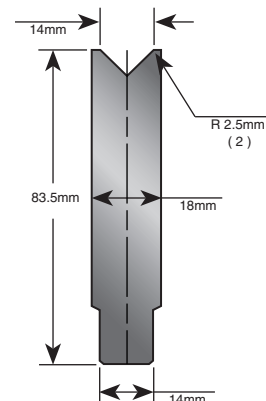

CATALOGUE NUMBER	MAX. TON per metre	L 835mm	S 415mm	X SECTIONALIZED
E42100	100			
E42101	100			
E42102	100			
E42103	100			
E42104	100			
E42105	100			
E42120	100			
E42121	100			
E42122	100			

*Note: Quick Change 1V Dies require die holder No. 43030.

V-opening modifications and die relief available at additional cost. Contact the sales desk for prices and lead times.

Nitrex™(HRC-60) is standard on the dies on this page at no additional cost.

Tel: +44 (0) 1793 831818
Email: sales@wilsontool.eu.com

Free Phone: 0800 373748
Free Fax: 0800 373758

Tel Free:
Fax Free:

1-800 70 90 09 Ireland
1-800 53 55 38 Ireland



Low Profile Quick Change 1V Dies

Cat. No. E42110 - E42114

Part No. E42110

90°

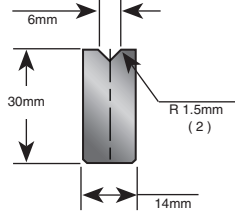

Part No. E42111

90°

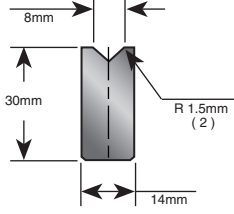

Part No. E42112

90°

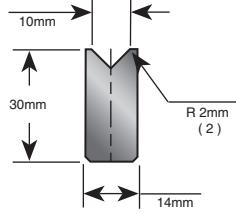

Part No. E42114

88°

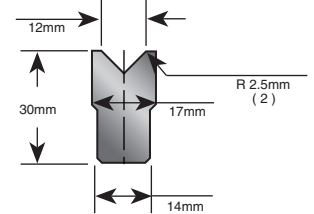

CATALOGUE NUMBER	MAX. TON per metre	S 415mm	X SECTIONALIZED
E42110	100		
E42111	100		
E42112	100		
E42114	100		

*Note: Low Profile Quick Change 1V Dies require die holder No.43030. Low Profile Quick Change 1V Dies No.E42110 and No.E42112 are available in 88° versions at additional cost.

V-opening modifications and die relief available at additional cost. Contact the sales desk for prices and lead times.

Nitrex™(HRC-60) is standard on the dies on this page at no additional cost.

Available in L (long) at additional cost.

Acute-Angle Quick Change 1V Dies

Cat. No. E42200 - E42205

Part No. E42200

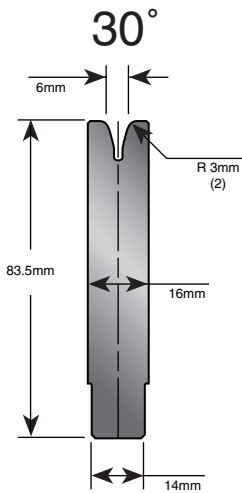

Part No. E42201

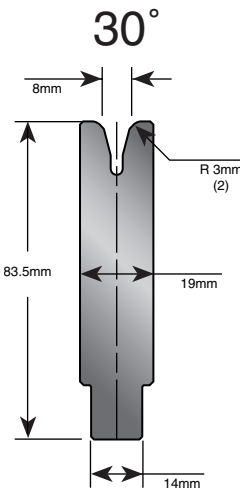

Part No. E42202

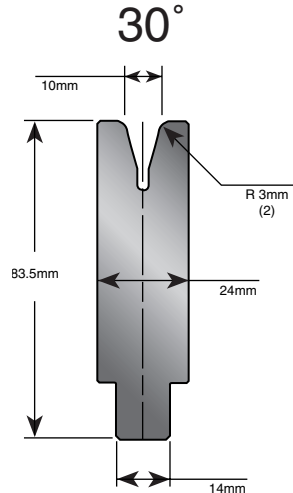

Part No. E42203

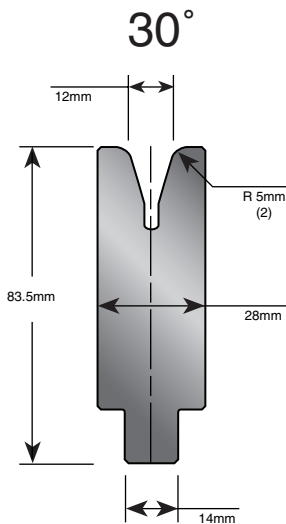

Part No. E42204

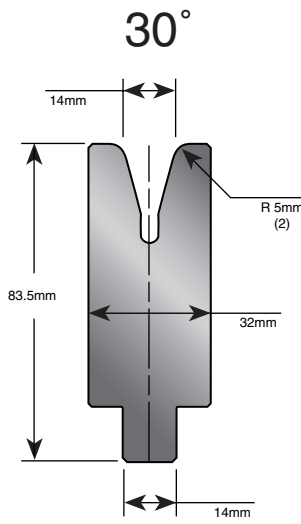

Part No. E42205

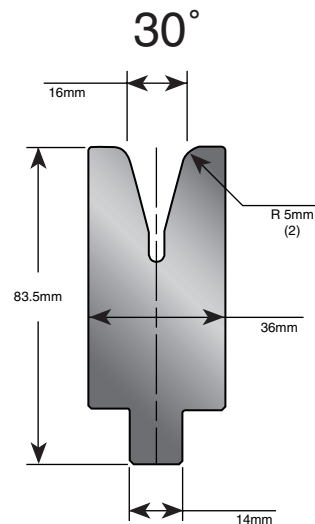

CATALOGUE NUMBER	MAX. TON per metre	L 835mm	S 415mm	X SECTIONALIZED
E42200	100			
E42201	100			
E42202	100			
E42203	100			
E42204	100			
E42205	100			

*Note: V-opening modifications and die relief available at additional cost. Contact the sales desk for prices and lead times.

Nitrex™(HRC-60) is standard on the dies on this page at no additional cost.

Tel: +44 (0) 1793 831818
Email: sales@wilsontool.eu.com

Free Phone: 0800 373748
Free Fax: 0800 373758

Tel Free: 1-800 70 90 09 Ireland
Fax Free: 1-800 53 55 38 Ireland



Quick Change 75° 1V Dies

Cat. No. E44200 - E44207

Part No. E44200

75°

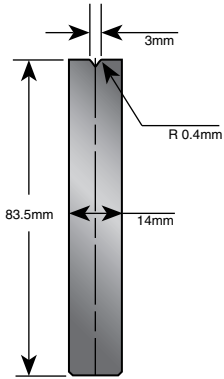

Part No. E44201

75°

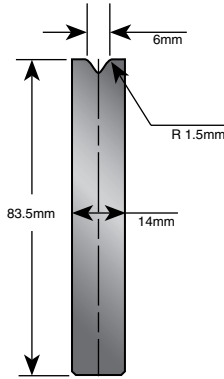

Part No. E44202

75°

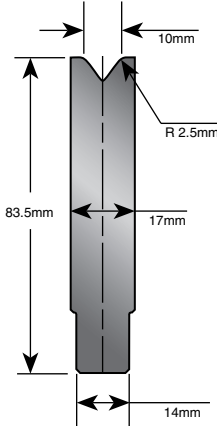

Part No. E44203

75°

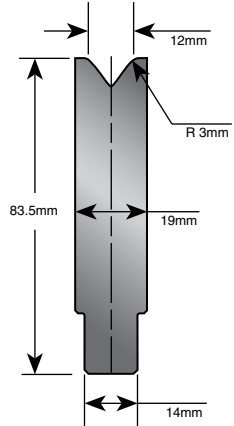

Part No. E44204

75°

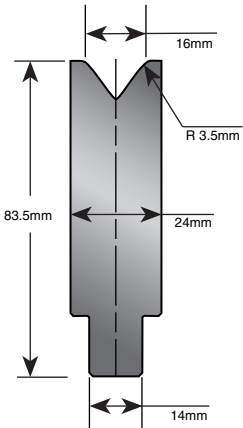

Part No. E44205

75°

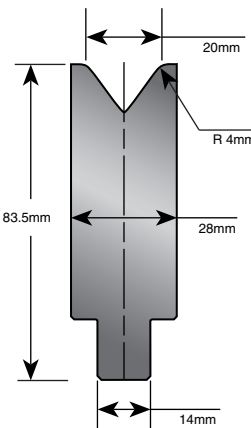

Part No. E44206

75°

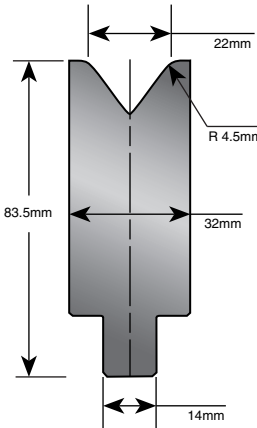

Part No. E44207

75°

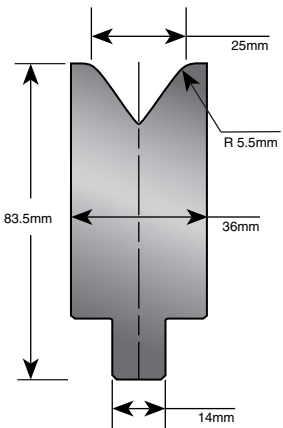

CATALOGUE NUMBER	MAX. TON per metre	L 835mm	S 415mm	X SECTIONALIZED
E44200	100			
E44201	100			
E44202	100			
E44203	100			
E44204	100			
E44205	100			
E44206	100			
E44207	100			

*Note: V-opening modifications and die relief available at additional cost. Contact the sales desk for prices and lead times.

Nitrex™(HRC-60) is standard on the dies on this page at no additional cost.

Quick Change 1V Die Holder And Wedge Block

Cat. No. 43030 and 43559



TOP VIEW

Part No. 43559



SIDE VIEW

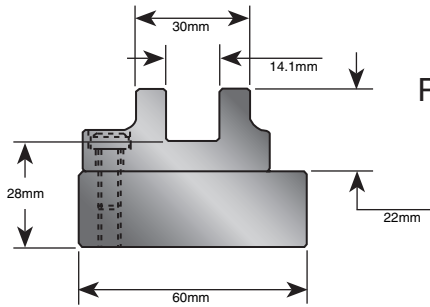

Part No. 43030

CATALOGUE NUMBER	L 835mm	S 415mm
43030		
43559		

*Note: Available with die tang. Contact the sales desk for prices and lead times.

Tel: +44 (0) 1793 831818
Email: sales@wilsontool.eu.com

Free Phone: 0800 373748
Free Fax: 0800 373758

Tel Free: 1-800 70 90 09 Ireland
Fax Free: 1-800 53 55 38 Ireland



Acute-Angle Large 1V Dies

Cat. No. E42300 - E42304

Part No. E42300

30°

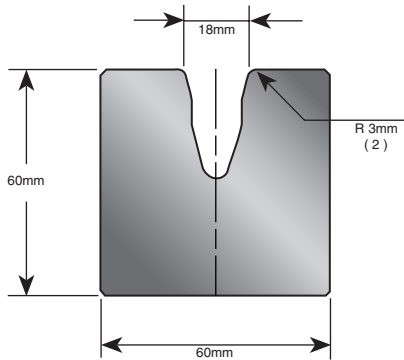

Part No. E42301

30°

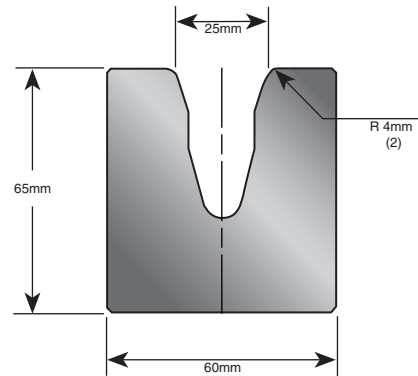

Part No. E42302

45°

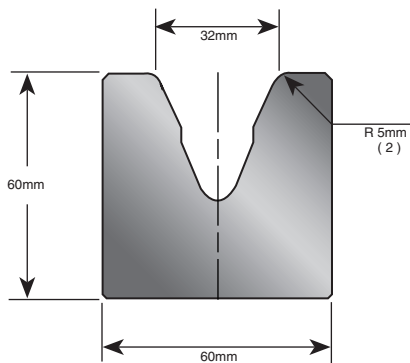

Part No. E42303

45°

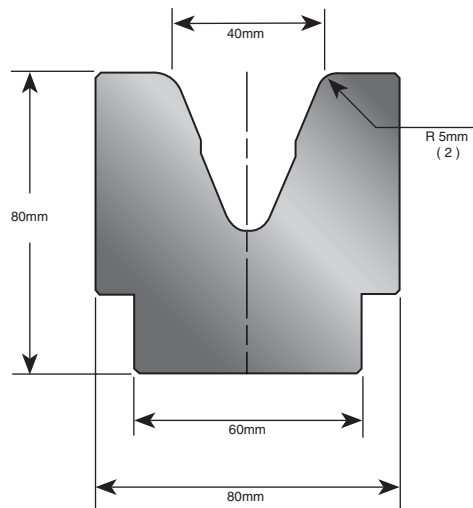

Part No. E42304

45°

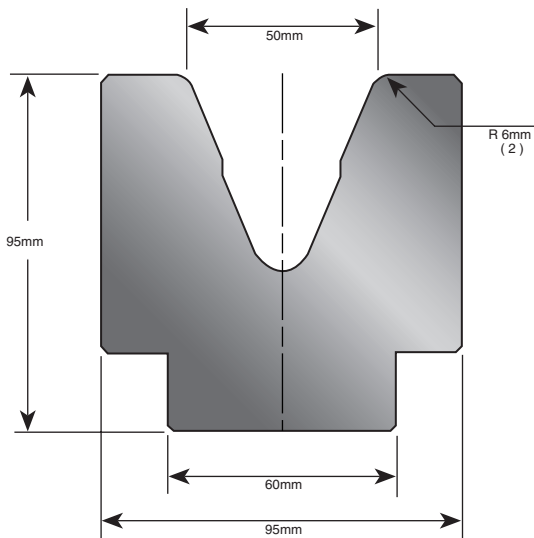

CATALOGUE NUMBER	MAX. TON per metre	L 835mm	S 415mm
E42300	80		
E42301	60		
E42302	40		
E42303	70		
E42304	70		

*Note: Acute-Angle Large 1V Dies may require die holder No.43040. Check height against machine stroke prior to ordering.

V-opening modifications and die relief available at additional cost. Contact the sales desk for prices and lead times.

Nitrex™ (HRC-60) available for every punch and die in the tooling range.

Large 1V Dies

Cat. No. E42400 - E42403

Part No. E42400
85°

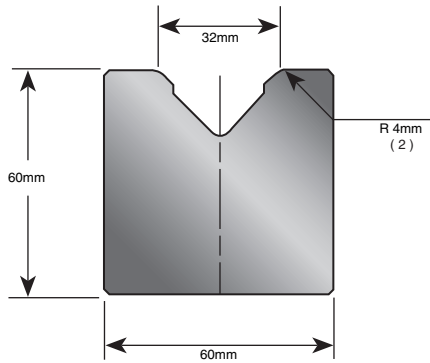

Part No. E42401
85°

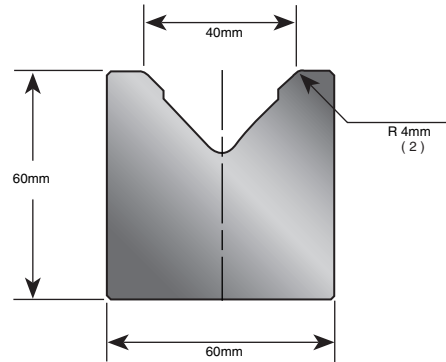

Part No. E42402
85°

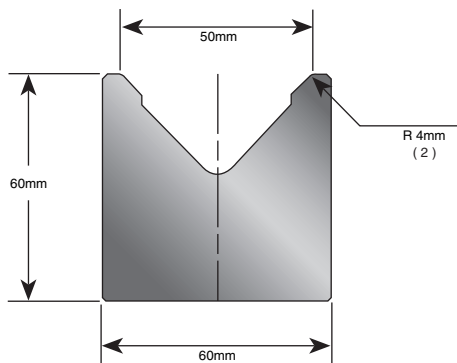

Part No. E42403
85°

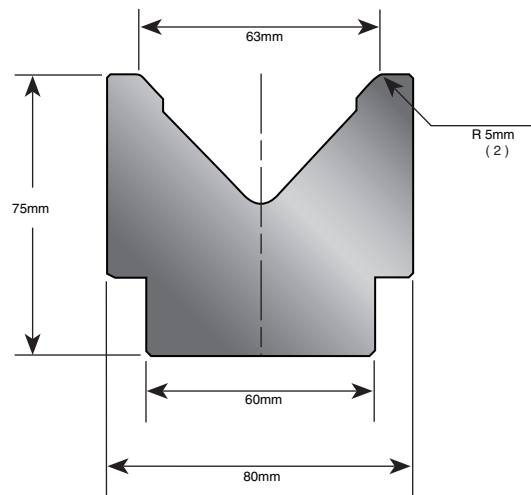

CATALOGUE NUMBER	MAX. TON per metre	L 835mm	S 415mm
E42400	100		
E42401	100		
E42402	100		
E42403	100		

*Note: Large 1V Dies may require die holder No.43040.

Check height against machine stroke prior to ordering.

V-opening modifications and die relief available at additional cost. Contact the sales desk for prices and lead times.

Nitrex™ (HRC-60) available for every punch and die in the tooling range.

Tel: +44 (0) 1793 831818
Email: sales@wilsontool.eu.com

Free Phone:
Free Fax:

0800 373748
0800 373758

Tel Free:
Fax Free:

1-800 70 90 09 Ireland
1-800 53 55 38 Ireland

Large 1V Dies

Cat. No. E42404 and E42405

Part No. E42404

85°

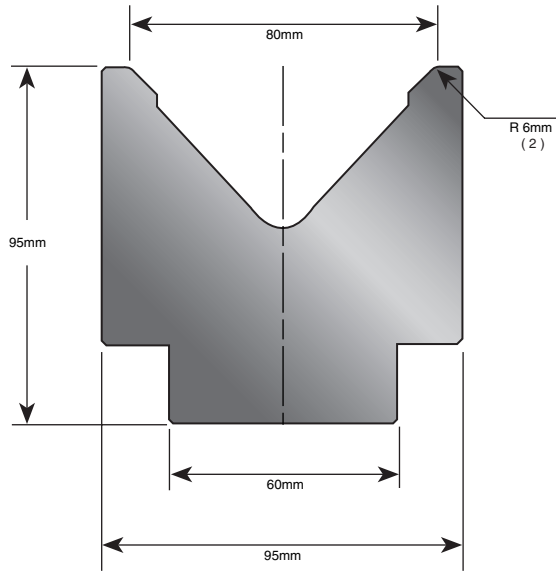

Part No. E42405

85°

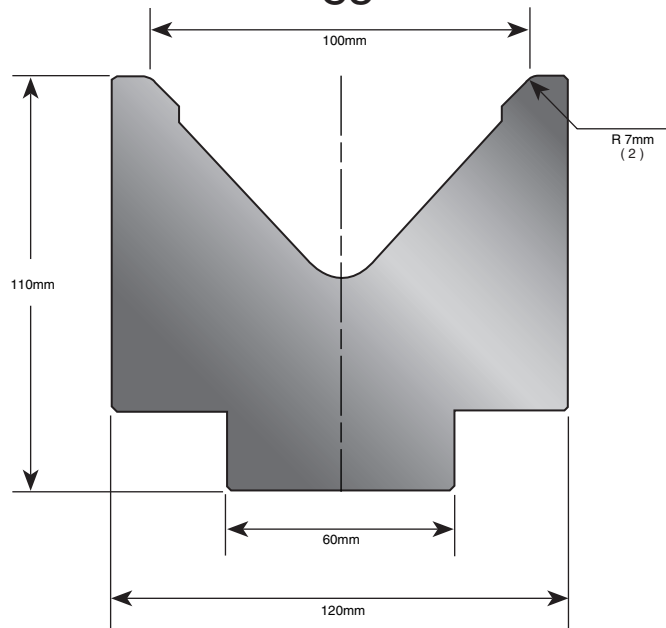

*Note: V-opening modifications and die relief available at additional cost.
Contact the sales desk for prices and lead times.

Nitrex™ (HRC -60) available for every punch and die in the tooling range.

Large 1V Dies

Cat. No. E42406

Part No. E42406

80°

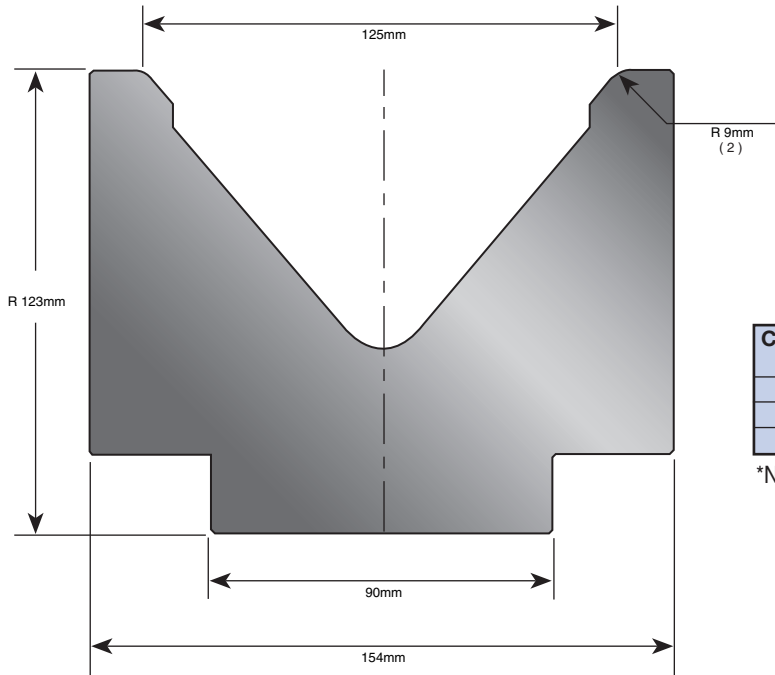

CATALOGUE NUMBER	MAX. TON per metre	L 835mm	S 415mm
E42404	100		
E42405	100		
E42406	100		

*Note: Large 1V Dies may require die holder No.43040. Check height against machine stroke prior to ordering.

Please check width of lower beam of press brake prior to ordering die No.42406.

V-opening modifications and die relief available at additional cost. Contact the sales desk for prices and lead times.

Nitrex™ (HRC-60) available for every punch and die in the tooling range.

Large 1V Die Holder

Cat. No. 43040

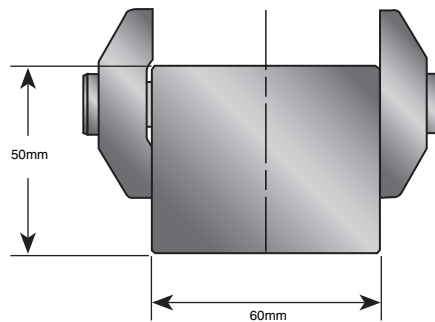

CATALOGUE NUMBER	L 835mm	S 415mm
43040		

Tel: +44 (0) 1793 831818
Email: sales@wilsontool.eu.com

Free Phone:
Free Fax:

0800 373748
0800 373758

Tel Free:
Fax Free:

1-800 70 90 09 Ireland
1-800 53 55 38 Ireland

Quick Change Rail Style Flattening Die

Cat. No. E42312

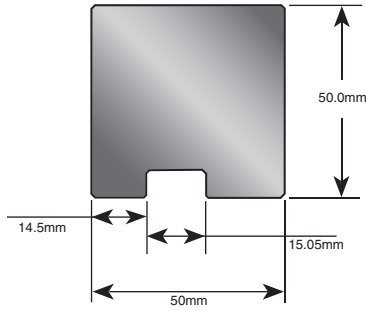

Part No. E42312

CATALOGUE NUMBER	MAX. TON per metre	L 835mm	S 415mm	X SECTIONALIZED
E42312	100	Call for pricing and lead time		

*Note: Designed to run with standard 2V Quick Change die system.

Custom heights available for stage bending. Contact the sales desk for pricing and lead times.

Nitrex™(HRC-60) is standard on the dies on this page at no additional cost.

3V Hemming Die

Cat. No. E42310

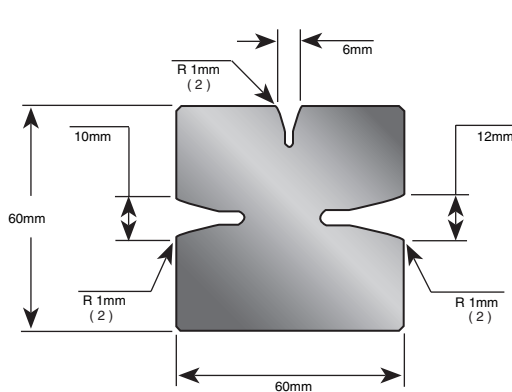

30°

Part No. E42310

CATALOGUE NUMBER	MAX. TON per metre	L 835mm	S 415mm
E42310	100		

*Note: Nitrex™(HRC-60) is standard on the dies on this page at no additional cost.

Flattening Die

Cat. No. E42311

Part No. E42311

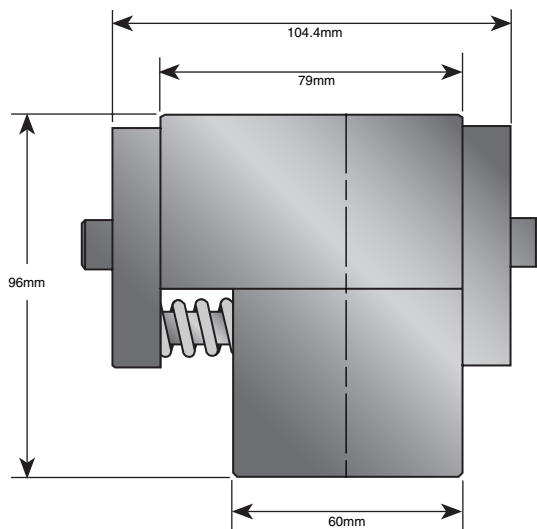

CATALOGUE NUMBER	MAX. TON per metre	L 835mm	S 415mm
E42311	100		

*Note: Nitrex™(HRC-60) is standard on the dies on this page at no additional cost.

Hemming Dies

Cat. No. E42601 - E42603 and E43522 - E43524

Part No. E42601

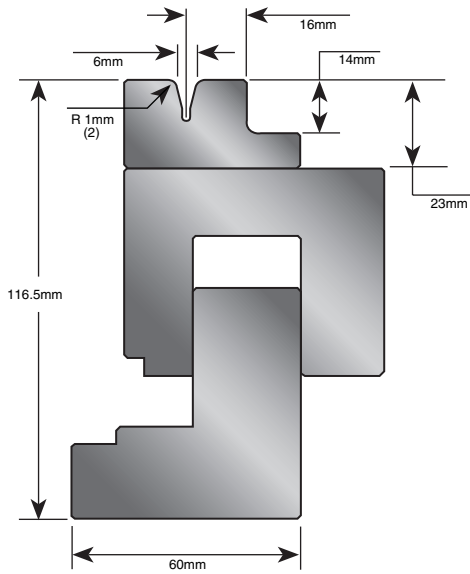

Part No. E42602

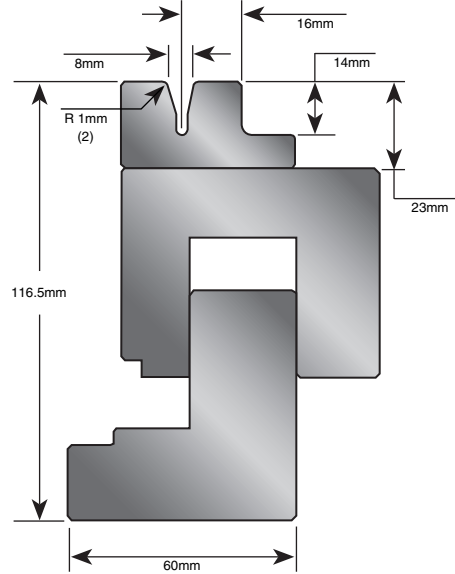

Part No. E42603

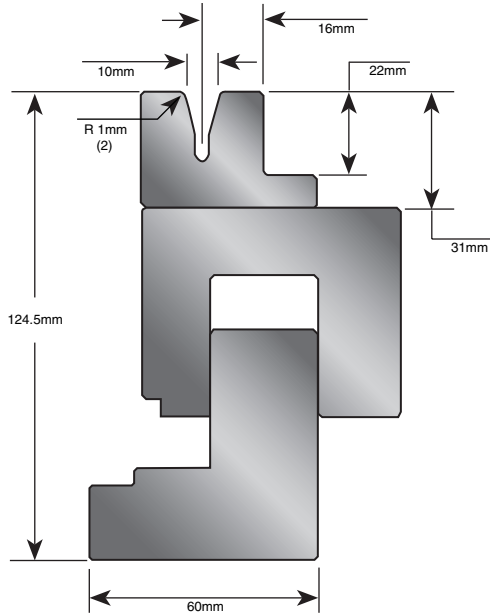

Replacement V-Blocks for Wilson Hemming Dies

Part No. E43522

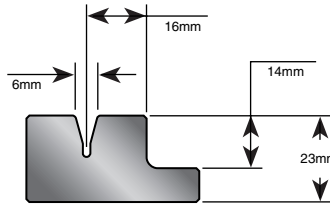

Part No. E43523

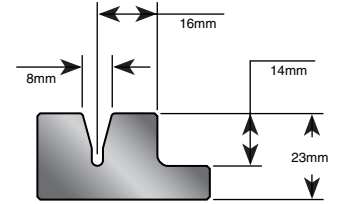

Part No. E43524

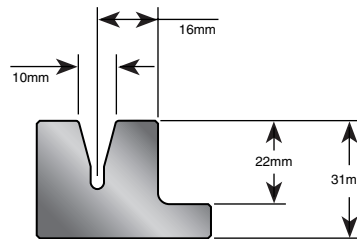

CATALOGUE NUMBER	MAX. TON per metre	MAX. MATERIAL	L 835mm	S 415mm
E42601	67	1.0mm		
E42602	67	1.5mm		
E42603	67	2.0mm		
E43522	67	1.0mm		
E43523	67	1.5mm		
E43524	67	2.0mm		

*Note: Nitrex™ (HRC-60) is standard on the dies on this page at no additional cost.

Tel: +44 (0) 1793 831818
Email: sales@wilsontool.eu.com

Free Phone: 0800 373748
Free Fax: 0800 373758

Tel Free: 1-800 70 90 09 Ireland
Fax Free: 1-800 53 55 38 Ireland



Urethane Holders

Cat. No. 42501 - 42504

Part No. 42501

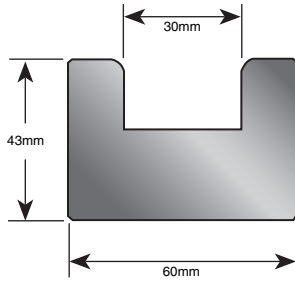

Part No. 42502

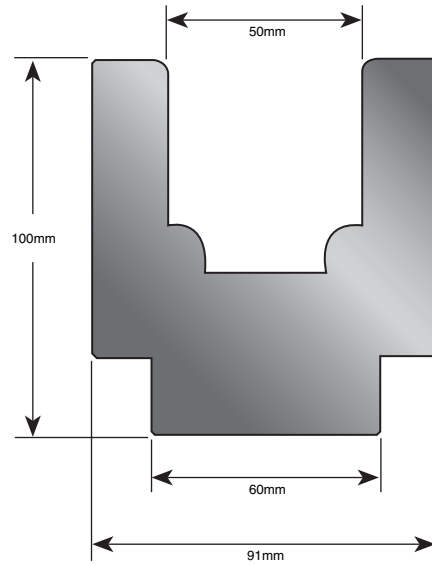

Part No. 42503

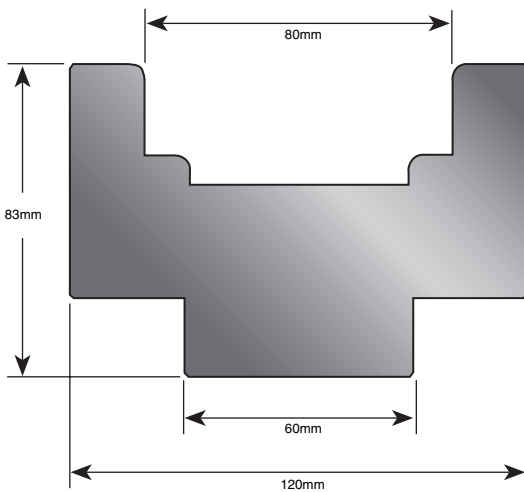

Part No. 42504

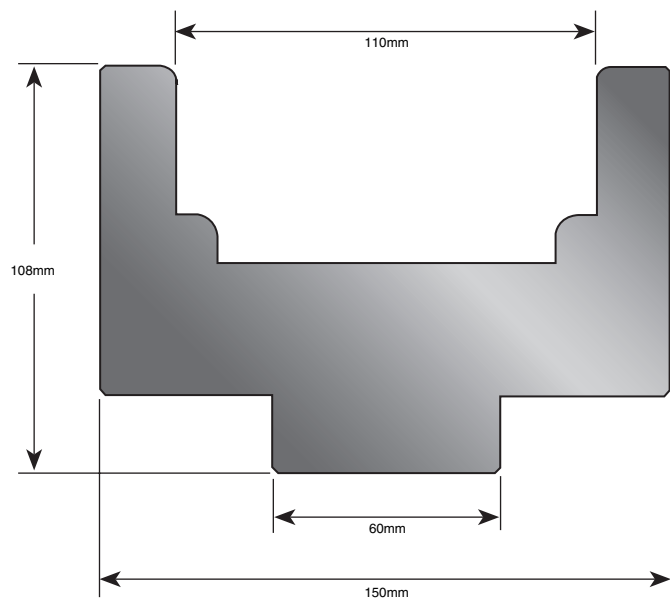

CATALOGUE NUMBER	L 835mm	S 415mm
42501		
42502		
42503		
42504		

*Note: All urethane die holders are machined from 6061-T6 aluminium.
Urethane holders may require die holder #43040.
Check height against machine stroke prior to ordering.

Urethane Pads

Cat. No. 42511 - 42524

Part No. 42511 and 42521

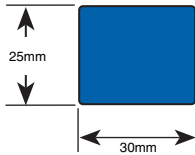

Part No. 42512 and 42522

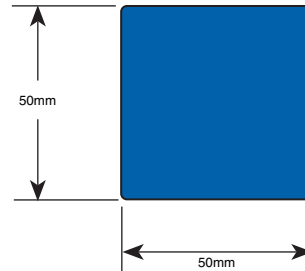

Part No. 42513 and 42523

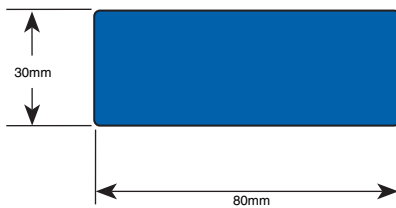

Part No. 42514 and 42524

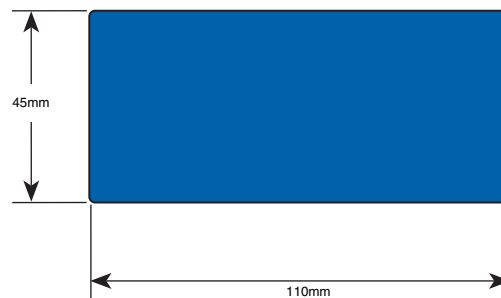

CATALOGUE NUMBER	SHORE HARDNESS	L 835mm	S 415mm
42511	80A / Red		
42521	90A / Blue		
42512	80A / Red		
42522	90A / Blue		
42513	80A / Red		
42523	90A / Blue		
42514	80A / Red		
42524	90A / Blue		

Tel: +44 (0) 1793 831818
Email: sales@wilsontool.eu.com

Free Phone: 0800 373748
Free Fax: 0800 373758

Tel Free: 1-800 70 90 09 Ireland
Fax Free: 1-800 53 55 38 Ireland



Rail Style Offset Tools

Cat. No. E43100 - E43106

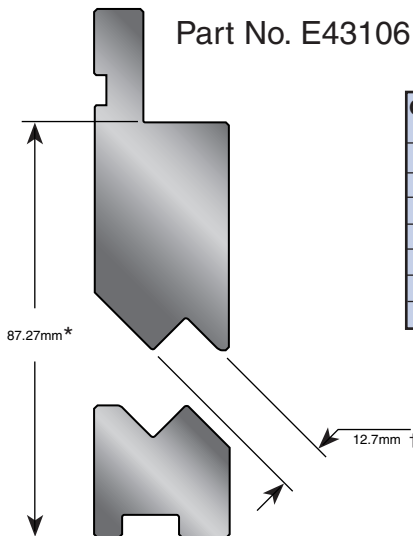
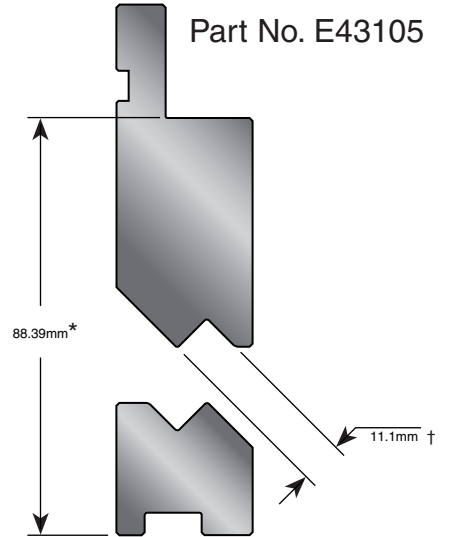
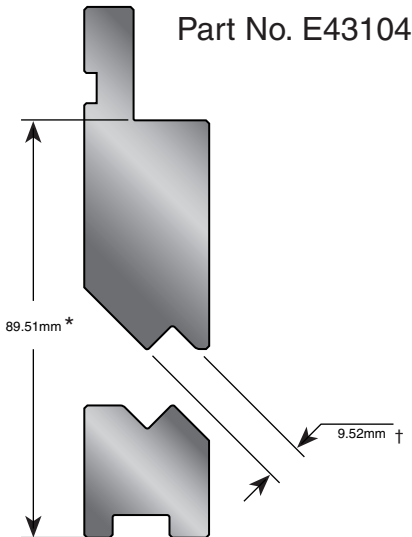
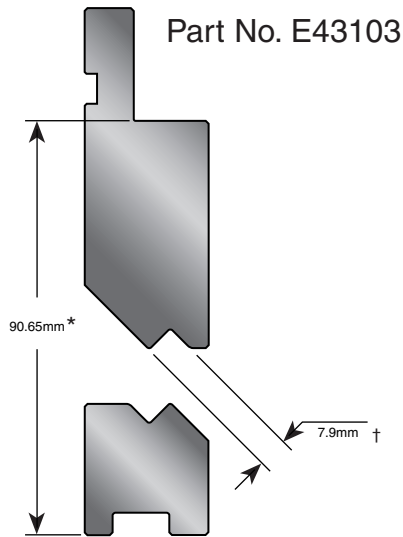
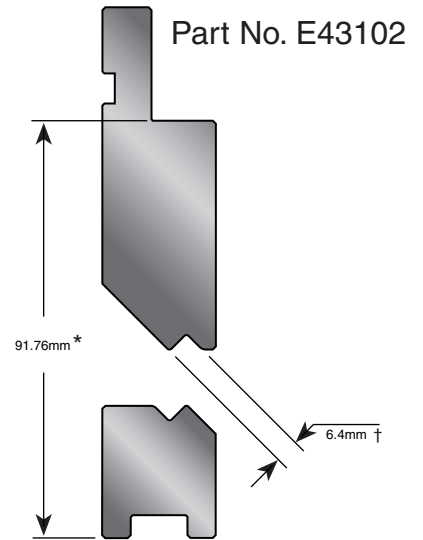
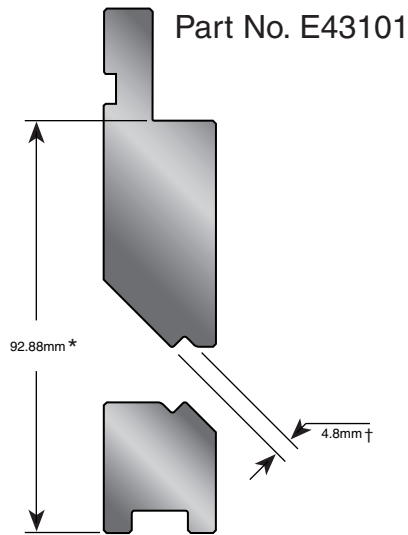
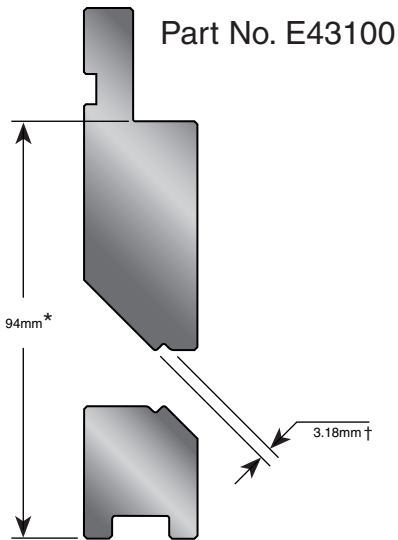

CATALOGUE NUMBER	MAX. TON per metre	MAX. MATERIAL	L 835mm	S 415mm	X SECTIONALIZED
E43100	100	1.0mm			
E43101	100	1.0mm			
E43102	100	1.0mm			
E43103	100	1.5mm			
E43104	100	1.5mm			
E43105	100	1.5mm			
E43106	100	1.5mm			

*Note: *Dimensions are for shut height requirements less material thickness.

†Offset height may vary as much as ±0.5mm after bending. All angles will be obtuse.

Special offset sizes are available at additional cost.

Nitrex™(HRC-60) is standard on the dies on this page at no additional cost.

Quick change offset tools are available at additional cost.

Side Gauge

Cat. No. 42701



CATALOGUE NUMBER	PRICE
42701	

*Note: Intended for use with Quick Change, 2V, Sectionalized 2V, and Quick Change 1V Dies.

Side Gauge and Protractor Assembly & Accessories

Cat. No. 42702, 42704, 42705



1V Die Stabilizer
Part No. 42704



Side Gauge and Protractor Assembly with Case
Part No. 42702

(Includes Cat. No. 42704 & No. 42705 stabilizers.)



2V Die Stabilizer
Part No. 42705

CATALOGUE NUMBER	PRICE
42702	
42704	
42705	

Quick Change Back Gauge Stopper Plate/Pads

Cat. No. 42703, 42707, 42708, 42709, 42712



Adjustable Back Gauge Stopper Plate
Part No. 42703

CATALOGUE NUMBER	PRICE
42703	

Replaces Original Pad
Part No. 42707



Single Point Pad
Part No. 42709



Reworkable Pad
Part No. 42712



Sheet Support Pad
Part No. 42708

CATALOGUE NUMBER	PRICE
42707	
42708	
42709	
42712	

*Note: Quick Change Back Gauge Stopper Pads are for Amada Style Back Gauges.

Tel: +44 (0) 1793 831818
Email: sales@wilsontool.eu.com

Free Phone:
Free Fax:

0800 373748
0800 373758

Tel Free:
Fax Free:

1-800 70 90 09 Ireland
1-800 53 55 38 Ireland

Narrow Punch Holders

Cat. No. 43000 and 43001

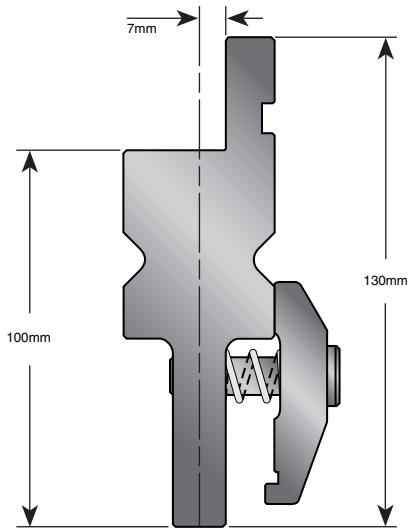

Part No. 43000

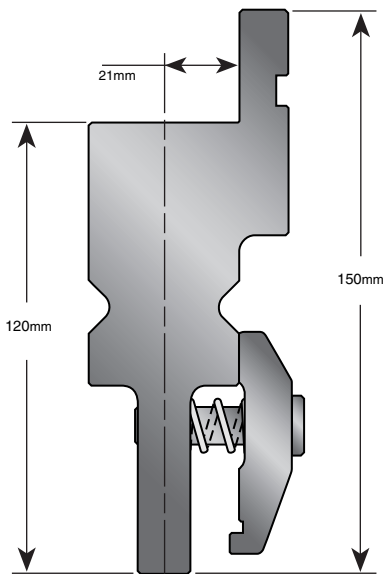
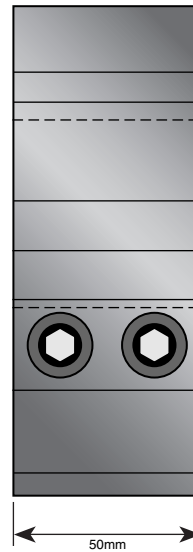

Part No. 43001

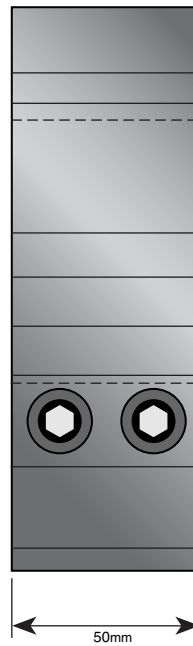

CATALOGUE NUMBER	50mm
43000	
43001	

Deep Punch Holder

Cat. No. 43002

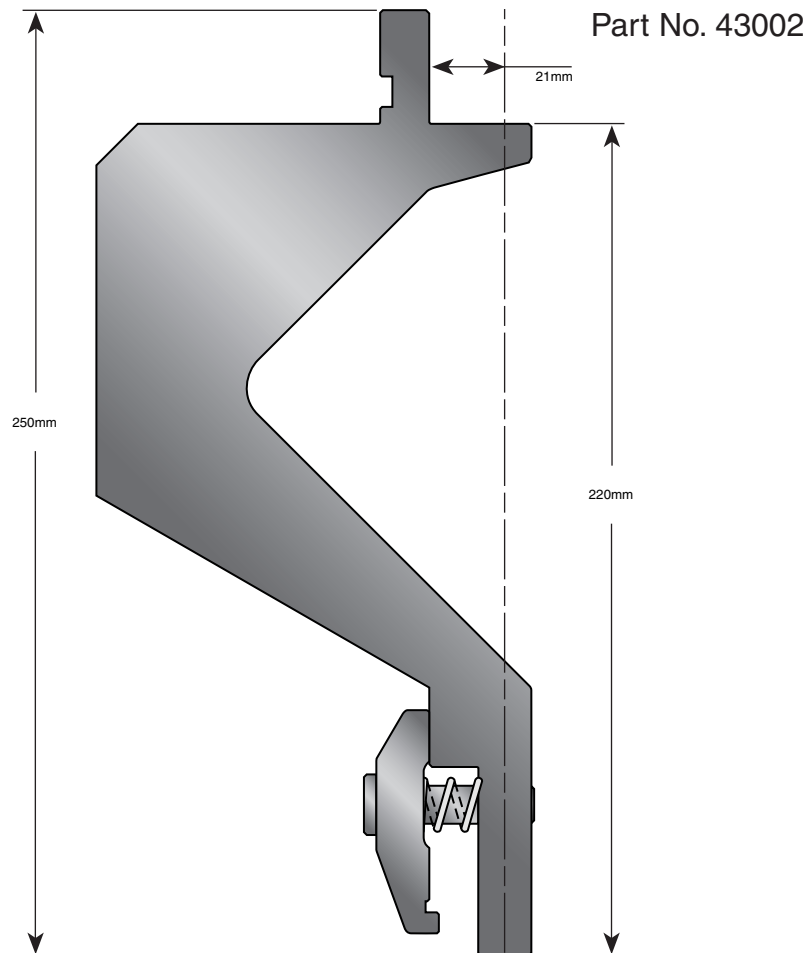

CATALOGUE NUMBER	MAX. TON per metre	150mm
43002	50	

Note: Punch holder No.43002 is available for Z2 style upper beams (rams) only.

Please consult the sales desk prior to ordering.

Tel: +44 (0) 1793 831818
Email: sales@wilsontool.eu.com

Free Phone:
Free Fax:

0800 373748
0800 373758

Tel Free:
Fax Free:

1-800 70 90 09 Ireland
1-800 53 55 38 Ireland

Stacking Punch Holder

Cat. No. 43003

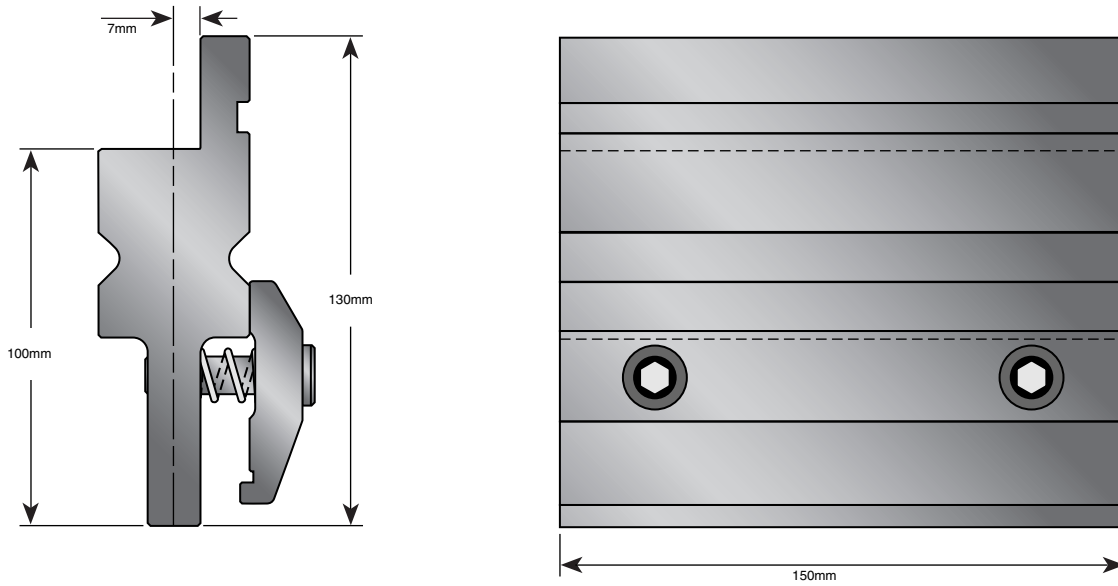

CATALOGUE NUMBER	150mm
43003	

Dual Clamping Kits

Cat. No. 42710, 42720, 43519, 43531

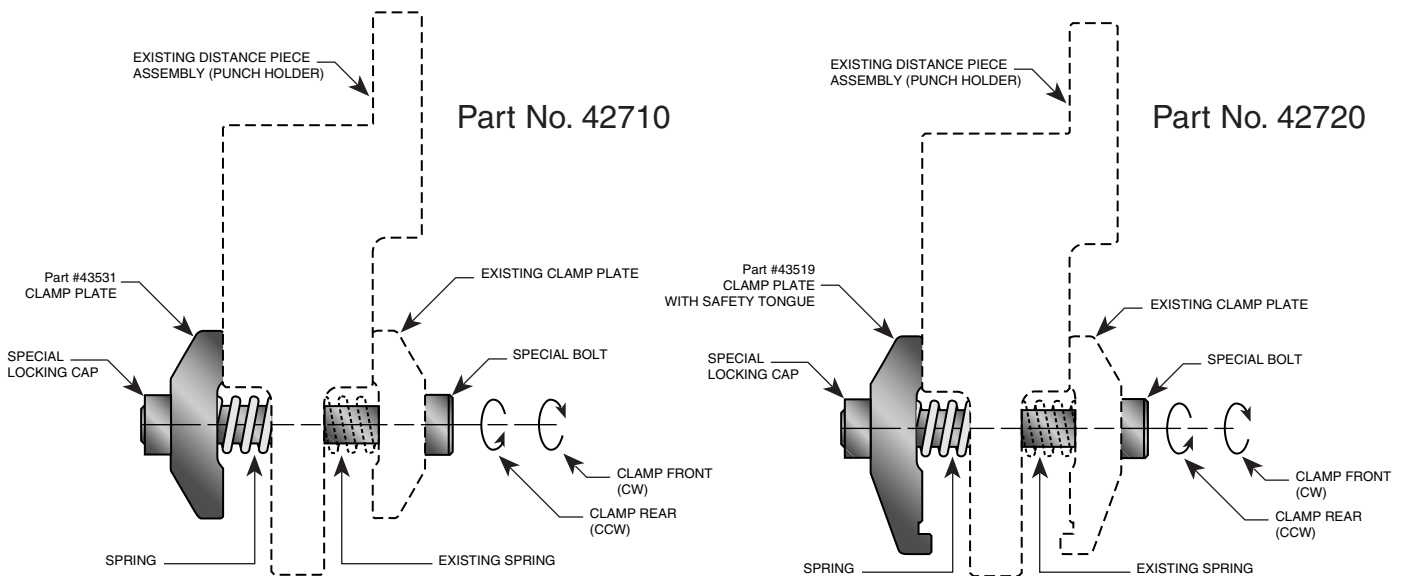

CATALOGUE NUMBER	150mm
42710	
42720	
43519	
43531	

European Punch Holders

Cat. No. 43005 and 43010

43005 For Conventional Press Brakes With Wedge

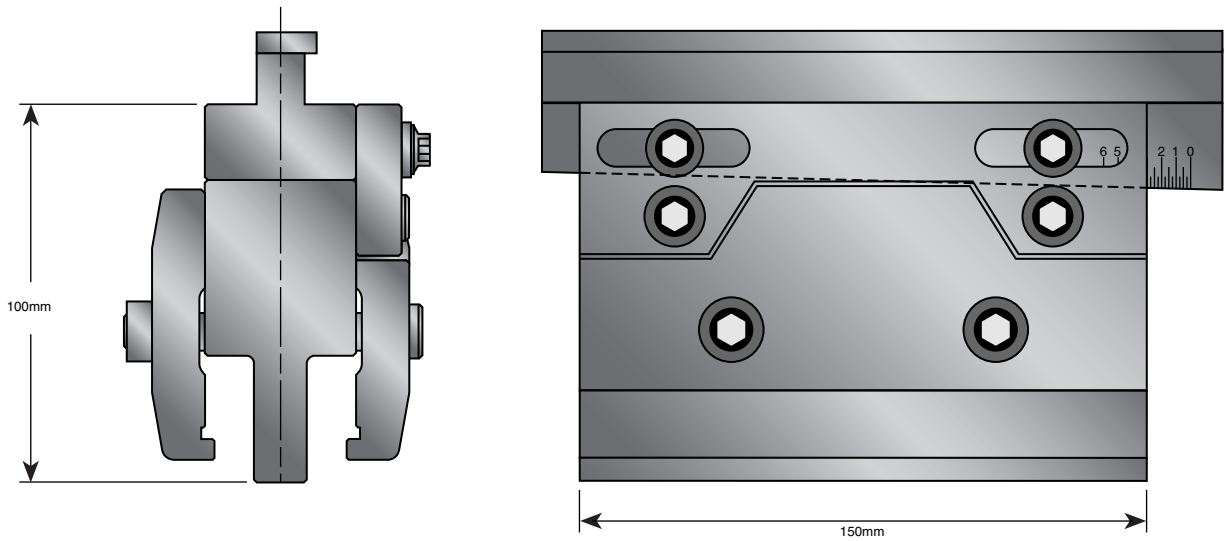

43010 For Conventional Press Brakes Without Wedge

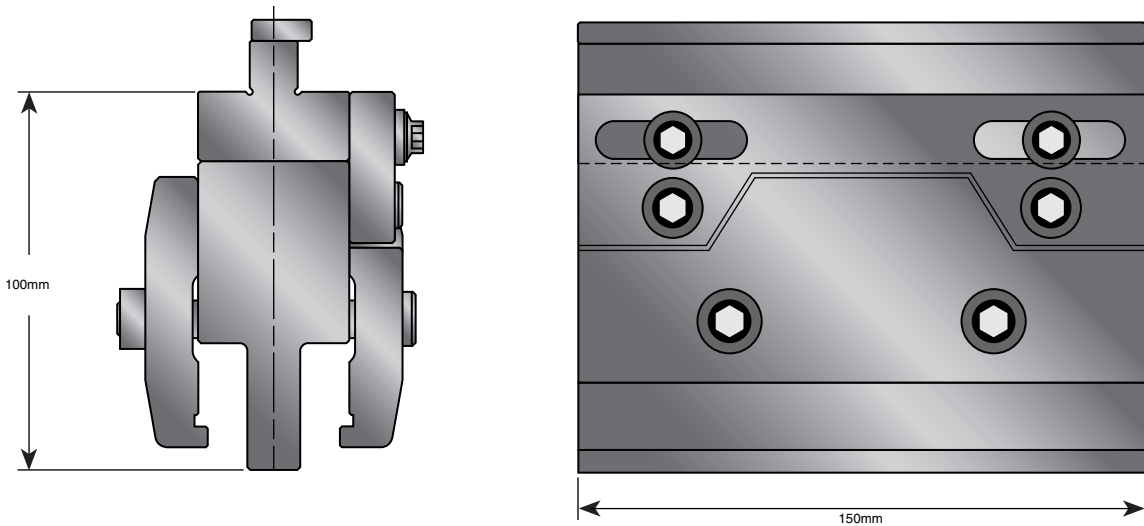

Tel: +44 (0) 1793 831818
Email: sales@wilsontool.eu.com

Free Phone:
Free Fax:

0800 373748
0800 373758

Tel Free:
Fax Free:

1-800 70 90 09 Ireland
1-800 53 55 38 Ireland

European Punch Holders

Cat. No. 43004 and 43007

43004 For Conventional Press Brakes Without Wedge

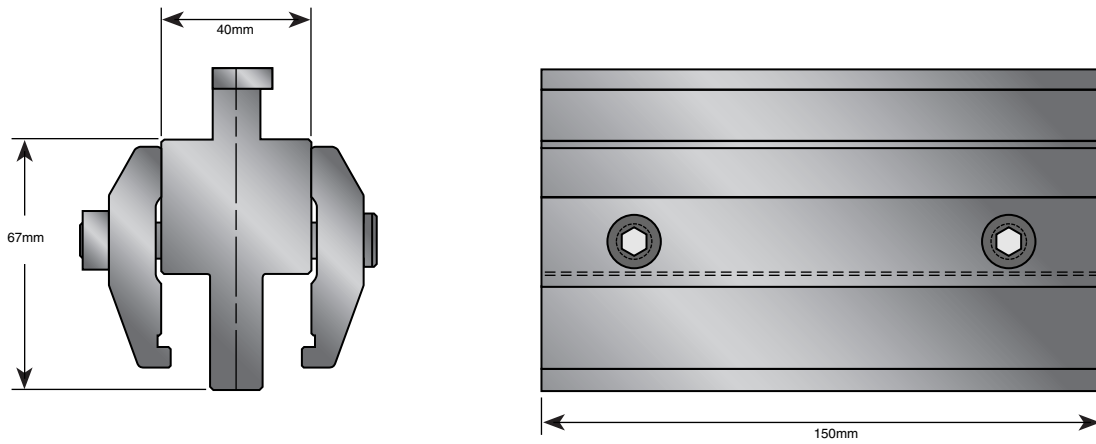

43007 Z1 Series With Wedge

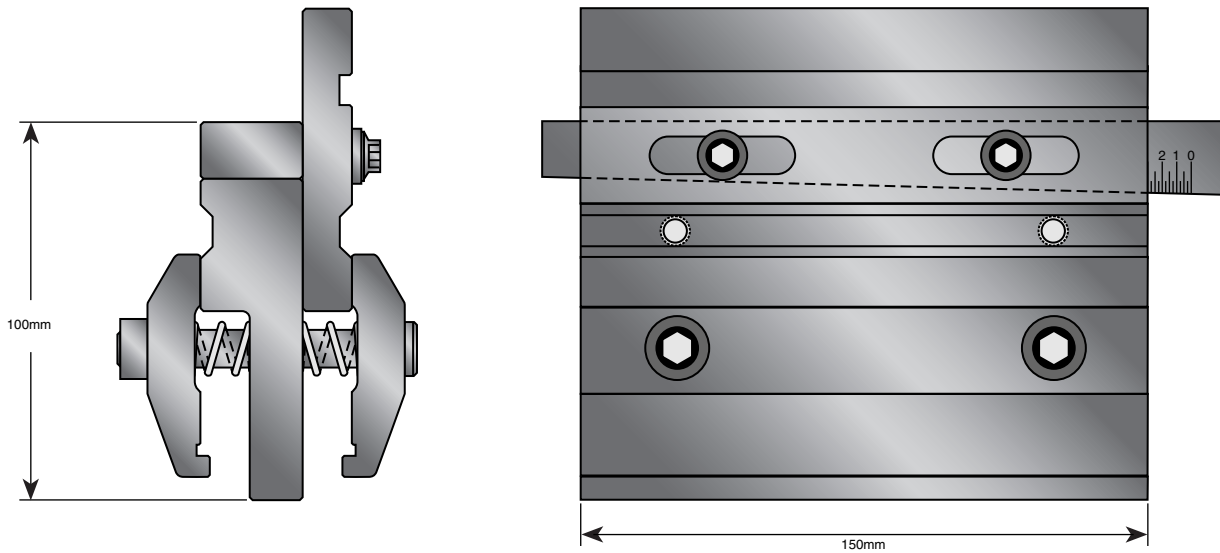

European Punch Holders

Cat. No. 43008 and 43009

43008

Z2 Series With Wedge

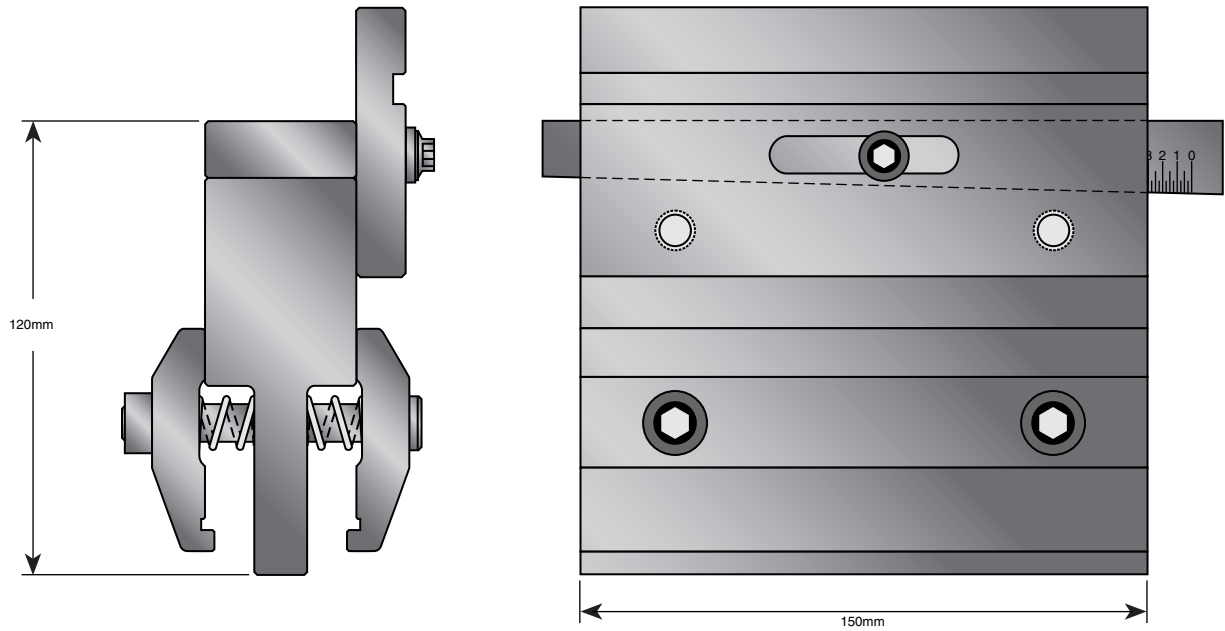

43009

For Trumpf Press Brakes With Wedge

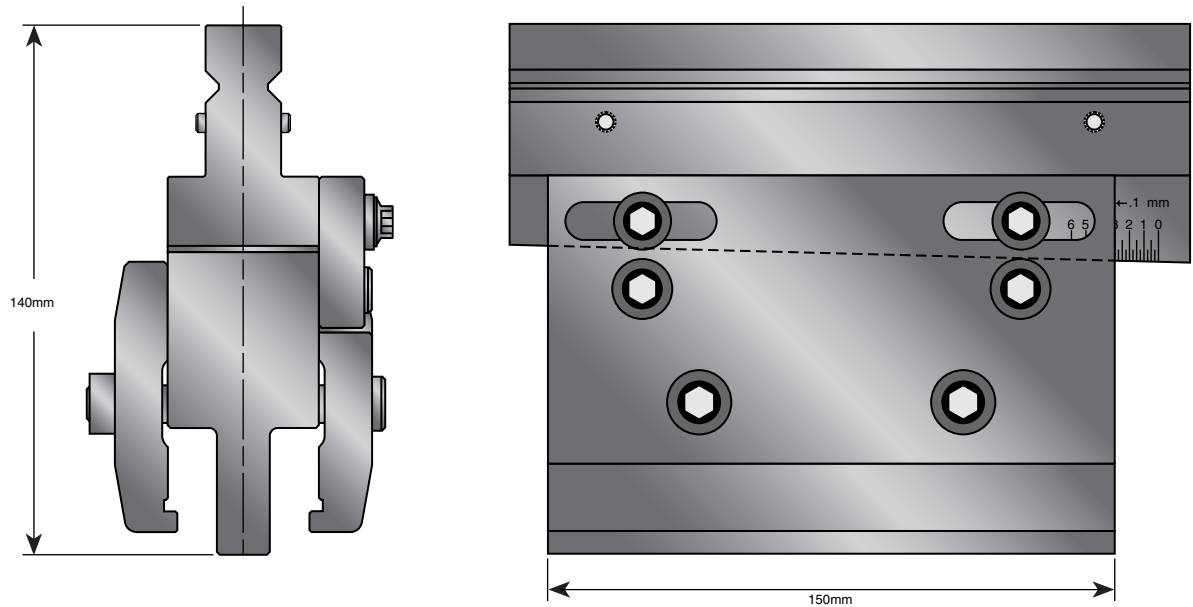

Tel: +44 (0) 1793 831818
Email: sales@wilsontool.eu.com

Free Phone:
Free Fax:

0800 373748
0800 373758

Tel Free:
Fax Free:

1-800 70 90 09 Ireland
1-800 53 55 38 Ireland

European Punch Holders

Cat. No. 43011

43011 For Trumpf Press Brakes Without Wedge

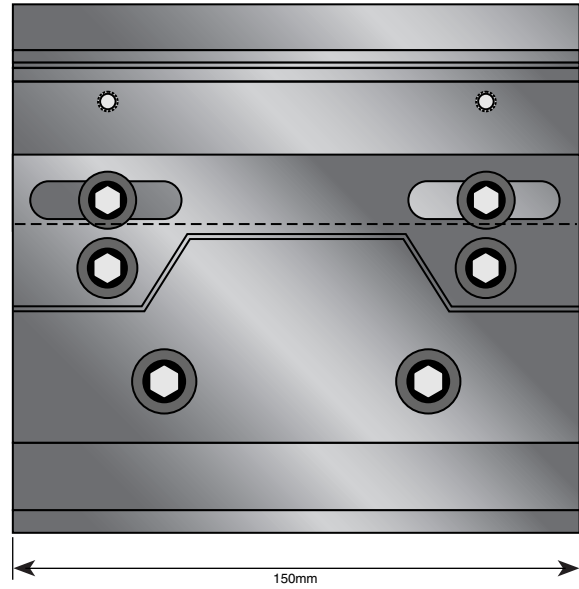
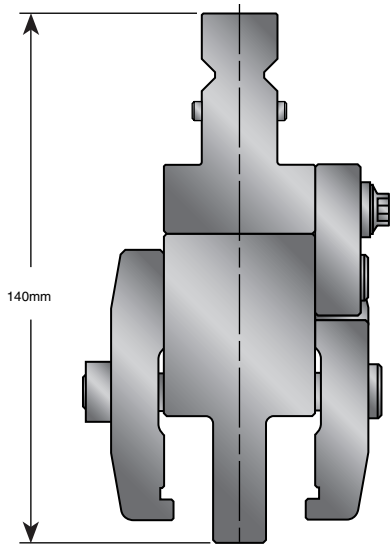

European Die Holders

Cat. No. 43006 and 43016

Part No. 43006

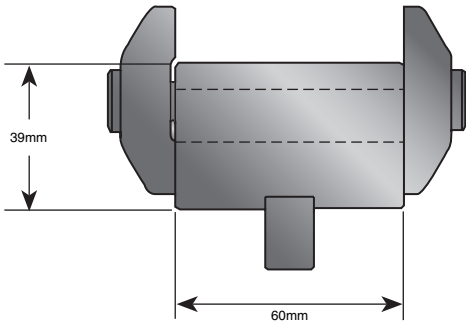

CATALOGUE NUMBER	L	S
43006	835mm	415mm

*Note: Please verify press brake tongue slot width when ordering.

Part No. 43016

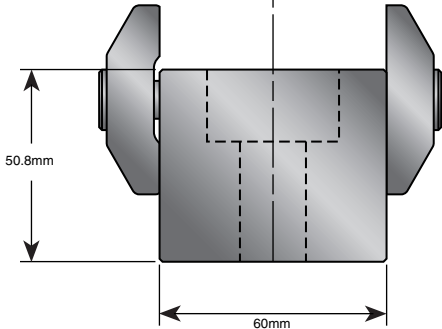

CATALOGUE NUMBER	
43016	Call for pricing information

*Note: Please contact the sales desk for a list of information that will be required prior to ordering.
 Solid piece made to length for bed of press brake.
 Please contact the sales desk.

Tel: +44 (0) 1793 831818
 Email: sales@wilsontool.eu.com

Free Phone:
 Free Fax:

0800 373748
 0800 373758

Tel Free:
 Fax Free:

1-800 70 90 09 Ireland
 1-800 53 55 38 Ireland



Wilson Press Brake Tooling Cabinet

Cat. No. 90007



Features:

- Solid steel construction
- Mobile base with heavy duty casters with a rated capacity of 408 kilograms each
- Three 177mm drawers capable of holding five punches each
- Two 50.8mm drawers capable of holding five dies each
- Punches are held upright in custom steel U-channels to prevent damage to tips and mounting tongues
- Dies are separated by custom U-channels to prevent damage to V-openings
- Individual latches on all drawers
- Safety interlock to prevent the opening of more than one drawer at a time
- Full width handles with end caps and paper labelling strips with clear protective label covers
- Retainer top with rubber mat
- Cabinet dimensions: 1067mm high, 1022.35mm wide, 571.5mm deep.



CATALOGUE NUMBER	PRICE
90007	

Urethane Rolls

Cat. No. 42530 and 42531



Urethane Rolls For Mark-Free Bending

CATALOGUE NUMBER	DIMENSIONS	30M
42530	0.4 x 152	
42531	0.8 x 152	

*Note: Urethane dies are also available for mark-free bending. Contact the sales desk for prices and lead times.

Visit us at www.wilsontool.com

“Our goal is to deliver the most reliable, innovative, durable, and consistent tools, such that our customers can be the most successful fabricators in the world.”

WILSON TOOL INTERNATIONAL

Wilson Tool International Ltd United Kingdom

Stirling Road, South Marston
Industrial Estate, Swindon,
Wiltshire, SN3 4TQ England
Tel (Free): 0800 373748
Tel: +44 (0) 1793 831818
Fax (Free): 0800 373758
Fax: +44 (0) 1793 831945
Email: sales@wilsontool.eu.com

Wilson Tool International France

19 rue Paul Seramy
77300 Fontainebleau, France
Tel (gratuit): 0800 90 84 88
Fax (gratuit): 0800 90 85 20
Email: ventes@wilsontool.eu.com

Wilson Tool International Germany

Gottlieb Daimler Str 2
31552 Rodenberg, Germany
Tel (Frei): 00800-9457668665
Tel: +49 5723 747 0
Fax (Frei): 00800-945766329
Fax: +49 5723 747 10
Email: verkauf@wilsontool.eu.com

Wilson Tool International A/S Denmark

Islevdalvej 100	Sweden	- 020 791 419
DK-2610	Norway	- 80 01 08 09
Roedovre, Denmark	Finland	- 0800 114 523
Tel: +45 44 53 1699		
Fax: +45 44 53 0607		
Email: sales@wilsontool.dk		

Wilson Tool International Inc. United States

12912 Farnham Avenue
White Bear Lake, MN 55110 USA
Tel (Free): 800-328-9646
Tel: 651-286-6001
Fax (Free): 800-222-0002
Fax: 651-286-5959
Email: marketing@wilsontool.com

Wilson Tool International China LLC

Rm 2F/C No.1076 Jiangning Road
Shanghai 200060 China
Tel: +86 21 62660958
Tel: +86 21 62662396
Fax: +86 21 62662364
Email: ldtool@guomai.sh.cn